

dozer blades

7900 SERIES

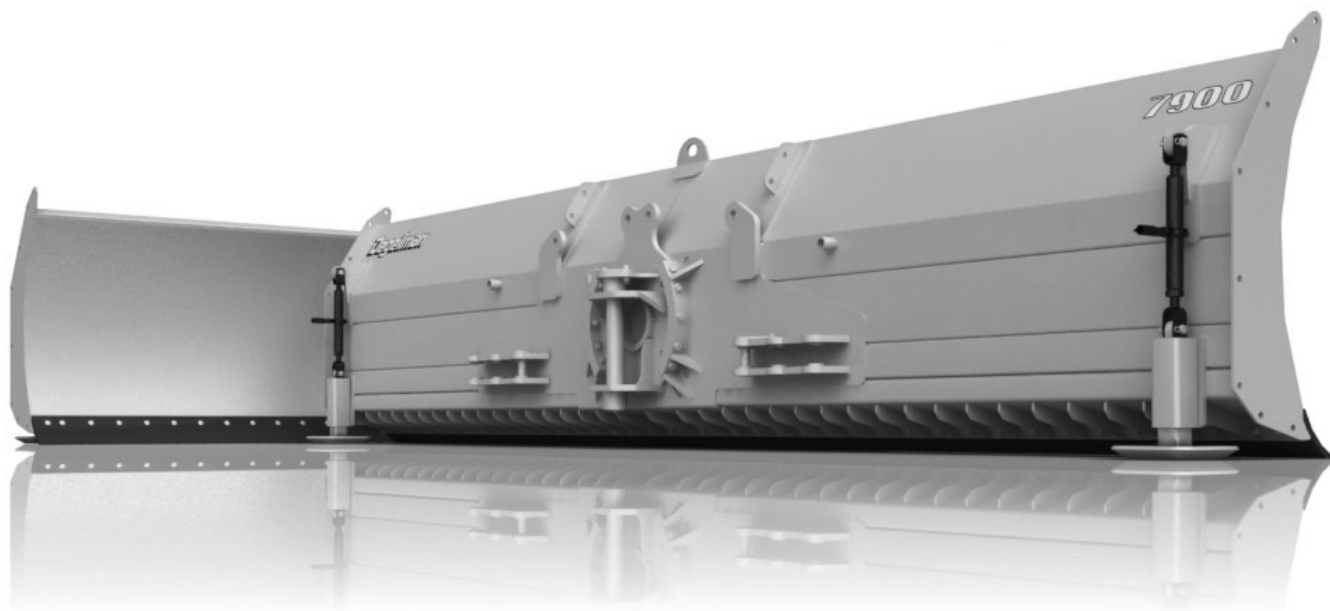

79Dlock

143203 v2.3

DEGELMAN INDUSTRIES LTD.
BOX 830-272 INDUSTRIAL DRIVE,
REGINA, SK, CANADA, S4P 3B1
FAX 306.543.2140 PH 306.543.4447
1.800.667.3545 DEGELMAN.COM

CASE STX/NH TJ 275, 325, 375-500
CASE STX QUADTRAC 375-500

Note: QuadTRAC models built before 01 Jan 2005, Below serial number: JEE0106701



79 D-lock

QUICK GUIDE INDEX

<i>Introduction</i>	<i>1</i>
<i>Safety</i>	<i>2</i>
<i>Operation</i>	<i>4</i>
<i>Maintenance</i>	<i>6</i>
<i>Transport & Storage</i>	<i>12</i>
<i>Troubleshooting</i>	<i>13</i>
<i>Blade Attachments</i>	<i>14</i>
<i>Blade Components</i>	<i>15</i>
<i>Pivot & Main Frame</i>	<i>16</i>
<i>Mounting Brackets</i>	<i>18</i>
<i>Hydraulic Brackets</i>	<i>19</i>
<i>Bracket Installation</i>	<i>20</i>
<i>Bracket Hose Routing</i>	<i>24</i>
<i>Cylinders</i>	<i>25</i>
<i>Hydraulic Routing</i>	<i>26</i>
<i>D-lock Operation</i>	<i>30</i>
<i>Mounting Procedure</i>	<i>31</i>
<i>Warranty</i>	<i>32</i>

Record Serial Number:

.....

Introduction

WELCOME

Degelman is proud to welcome you to our rapidly increasing family of high quality and dependable product owners. This product was designed and built specifically for you, the customer. Through our research and with your input and feedback, we present to you our 7900 Series Dozer Blade.

Designed with durability, safety, and performance in mind, this dozer blade is ready for years of quality service. In order to help you keep your dozer blade in top operating condition we have provided you with this manual.

ABOUT THIS MANUAL

This manual has been designed to help you with three extremely important issues: **Operation, Safety, and Maintenance**. It is strongly recommended that you read through the entire manual and review it annually for:

- your own personal safety.
- the safety of others.
- helpful and effective operation techniques.
- maintenance procedures.
- preventative maintenance.

Your authorized Degelman dealer can be contacted for ordering any replacement parts, decals, or manuals. Since many of our parts are specially designed specifically for this dozer blade we strongly recommend you always replace them with genuine Degelman parts only.

This manual and its contents were current at the time of its first printing. To increase product performance and operation, some part modifications and changes may occur that are not reflected in this manual.

Note: The description "Right" or "Left" as used in this manual is determined by the direction the tractor will travel while in use (unless otherwise stated).

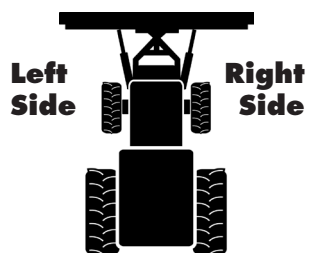

PROOF OF OWNERSHIP

Serial Number Plate



Your **serial number** is found on the serial number plate.

It is important to record the serial and model number of your dozer for proof of ownership and for any required service or maintenance assistance.

Serial Number _____

Owner Name _____

Model _____

Purchase Date _____

Dealer Name _____

Address _____

Phone _____

DESCRIPTION

The **7900 Dozer Blade** consists of a dozer blade connected to a pivot/main frame assembly.

Typically, this assembly mounts to side and axle brackets that are bolted securely onto the frame of your tractor.

The blade is attachable/detachable with a simple D-lock mounting system and hydraulic hook-up.

The 7900 Blade has three hydraulically controlled ranges of motion – lift, angle & tilt.

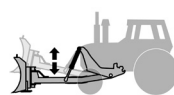

Lift

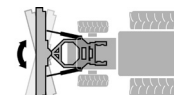

Angle

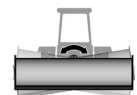

Tilt

Why is SAFETY important to YOU?

3 BIG Reasons:

- Accidents Can Disable and Kill
- Accidents Are Costly
- Accidents Can Be Avoided

SAFETY ALERT SYMBOL



The Safety Alert Symbol means:

**ATTENTION!
BECOME ALERT!
YOUR SAFETY IS INVOLVED!**

The Safety Alert Symbol identifies important safety messages applied to the dozer blade and in this manual. When you see this symbol, be alert to the possibility of **injury or death**. Follow the instructions provided on the safety messages.

SIGNAL WORDS

Note the use of the Signal Words: **DANGER**, **WARNING**, and **CAUTION** with the safety messages. The appropriate Signal Word has been selected using the following guidelines:

DANGER: Indicates an imminently hazardous situation that, if not avoided, **WILL** result in death or serious injury if proper precautions are not taken.

WARNING: Indicates a potentially hazardous situation that, if not avoided, **COULD** result in death or serious injury if proper precautions are not taken.

CAUTION: Indicates a potentially hazardous situation that, if not avoided, **MAY** result in minor or moderate injury if proper practices are not taken, or, serves as a reminder to follow appropriate safety practices.

YOU are RESPONSIBLE

... for your own safety and that of others!

- If you are not familiar with basic agriculture & industrial safety, you must get training.
- Owners of equipment must give operating instructions to other operators such as family members or a hired hand.
- Making any design changes to equipment could cause a hazard, damage your machine & void your warranty.

YOU are responsible for the SAFE operation and maintenance of your Degelman implement. YOU must ensure that you and anyone else who is going to operate, maintain, or work around the machine be familiar with the operating and maintenance procedures, and related SAFETY information contained in this manual. This manual will take you step-by-step through your working day and will alert you to good safety practices that should be adhered to while operating this equipment.

Remember, YOU are the key to safety. Good safety practices not only protect you, but also the people around you. Make these practices a working part of your safety program. Be certain that EVERYONE operating this equipment is familiar with the recommended operating and maintenance procedures and follows all the safety precautions. Most accidents can be prevented. Do not risk injury or death by ignoring good safety practices.

- Owners must give operating instructions to operators or employees before allowing them to operate the unit, and at least annually thereafter per OSHA regulation 1928.57.
- The most important safety device on this equipment is a SAFE operator. It is the operator's responsibility to read and understand ALL Safety and Operating instructions in the manual and to follow these. All accidents can be avoided!
- A person who has not read and understood ALL operating and safety instructions is not qualified to operate the machine. An untrained operator exposes himself and bystanders to possible serious injury or death.
- Do not modify the equipment in any way. Unauthorized modification may impair the function and/or safety and could affect the life of the equipment.

Safety

GENERAL SAFETY

1. Read and understand the Operator's Manual and all safety signs before using. Review safety related items with all operators annually.
2. Lower blade to ground, stop tractor engine, place all controls in neutral, set park brake and remove ignition key before servicing, adjusting or repairing.
3. Keep hands, feet, hair and clothing away from all moving and/or rotating parts.
4. DO NOT allow riders on the machine or tractor during operation or transporting.
5. Clear the area of all bystanders, especially children, before starting.
6. DO NOT operate machine on steep side hills or slopes.
7. Be careful when working around or maintaining a high-pressure hydraulic system. Ensure all components are tight and in good repair before starting.
8. Clean all reflectors, lights and the SMV sign before transporting on a highway or public road. Be sure to check with local highway authorities and comply with their lighting requirements.
9. Stay well back from machine when operating. Keep others away.
10. DO NOT operate the Dozer without an adequate amount of rear wheel ballast.

Prepare for Emergencies

- Keep a first aid kit and fire extinguisher handy.
- Keep emergency numbers for doctor, hospital, ambulance, and fire department near your phone.

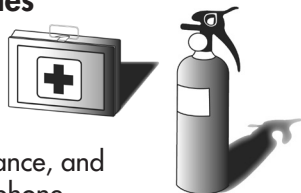

Doctor _____

Ambulance _____

Hospital _____

Fire Department _____

Wear Protective Equipment

Note: Before working on machine, always turn tractor off, set controls in neutral, and remove ignition key.

- Wear proper safety equipment such as safety glasses and shoes, hearing protection, hard hats, or any other appropriate items to prevent injury.
- Loss of hearing or hearing impairment may result from prolonged exposure to loud noise. Wear suitable hearing protective devices such as earmuffs or earplugs to protect your hearing.
- Safely operating this equipment requires the full attention of the operator. Do not wear radio or music headphones, or talk on your phone while operating this machine. Never operate while under the influence of alcohol or drugs or allow anyone under the influence to operate the tractor.

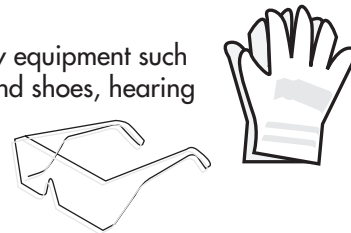

⚠️ HYDRAULIC

- Keep all parts clean.
- Replace worn or damaged parts.
- Don't try any makeshift repairs.
- Before operating check that everything is tight and not broken.
- Wear gloves and eye protection when searching for leaks. Use a piece of wood or cardboard but not your hand. High pressure oil will penetrate your skin. If that happens you risk serious injury.

⚠️ BLADE

- Lower blade to the ground when not in use.
- Keep clear of blade when tractor is running.
- Keep hands & feet away from under blade.
- Turn engine off when hooking up hydraulics and engaging D-lock during mounting or dismounting.

⚠️ TRANSPORTING

- Lift blade up then hold with safety chain.
- Make sure SMV sign & reflectors are clean.
- Use your hazard lights.



Operation

TO THE NEW OPERATOR OR OWNER

The Degelman Dozer Blade is a push type tractor attachment designed primarily for excavating, levelling and filling of dirt, snow and silage.

It is the owners or operators responsibility to read this manual carefully to learn how to operate the machine safely and how to set it to provide maximum efficiency. Safety is everyone's business. By following safe operating practices, a safe environment is provided for the operator and bystanders.

The manual will take you step-by-step through your working day. By following the operating instructions in conjunction with a good maintenance program your machine will provide many years of trouble-free service.

PRINCIPLES OF OPERATION

The dozer blade consists of a blade/cutting edge unit attached to a pivot-main frame combination suspended from the tractor by the front and side mount brackets. By driving the tractor forward with the blade either straight ahead or angled, and allowing the cutting edge to run just under the ground surface - dirt, silage or snow is relocated as desired.

BREAK-IN

Although there are no operational restrictions on the Dozer Blade when it is new, there are some mechanical checks that must be done to ensure the long term integrity of the unit. When using the machine for the first time, follow this procedure:

A. Before using:

1. Read Operator's Manual.
2. Lubricate all points shown in the Maintenance Section.
3. Check all bolt tightness.

B. After operating for 2 hours:

1. Check all hardware.
2. Check all hardware tightness.
3. Check all hydraulic system connections. Tighten if any are leaking.

C. After operating 10 hours:

1. Repeat Step B.
2. Go to the service schedule as outlined in the Maintenance Section.

TRACTOR PREPARATION

1. Wheel Spacing

 **Important:** To avoid possible damage from over stressing tractor axles, use no tire combination which results in overall width greater than the width of the angle blade.

 **Important:** Before beginning operation, turn the wheel fully to the right and left to be sure there is sufficient clearance between the tires and the angling cylinders. If necessary, move the wheels to a wider setting to provide clearance. See your Tractor Operator's Manual.

2. Rear Wheel Weight and Tire Inflation:

Add necessary rear end weights for efficient operation and safety. Any of the cast-iron weights recommended for your tractor or liquid in the tires, may be used for necessary ballast. Be sure the weight is distributed equally on each rear wheel.

Inflate front and rear tires to proper pressure as recommended in the Tractor Operator's Manual for heavy front-mounted implements.

3. Checking Hydraulic Oil Level:

Check the oil level in the tractor hydraulic system daily. Refer to your tractor operator's Manual for Instructions. Keep the oil supply up to the proper level. Before checking oil supply, fully extend and retract angle and lift cylinders 3 - 4 times and return the blade to the ground.

ATTACHING THE DOZER BLADE

NOTE: Please refer to the assembly section of this manual - for full instructions for attaching your specific tractor and blade model.

BLEEDING THE HYDRAULICS

Before beginning operation, bleed the hydraulic system to remove any air. To do this, cycle the hydraulics several times by holding the cylinder fully extended for several seconds. This will cause any trapped air to be purged from cylinder.

COLD WEATHER OPERATION

To assure smooth operation in cold weather, cycle the cylinders several times to warm the oil in the hydraulic system.

Operation

OPERATOR'S RESPONSIBILITY

Every operator should read this manual and be instructed in safe operating procedures. An untrained operator is not qualified to operate this machine and could place themselves or bystanders in danger.

OPERATING SPEED

For normal operation, operate the tractor at a comfortable or manufacturer recommended speed. When operating over rough terrain or limited to space, reduce engine speed. The actual forward speed will be determined by tractor horsepower, land density and depth of cut.

Experience will teach you the most efficient operating speed, but as a rule 3-4 MPH (5-7 km/h) is a normal operating range.

FLOATING THE DOZER BLADE

Here are some the things you can do with your hydraulic system in float position:

- Skim the top of pavement
- Run on the skid shoes
- Back drag

By placing the remote cylinder operating lever for the lift function in float position, the blade may be used to smooth an area by running the tractor in reverse (refer to Tractor Operator's Manual). On moderate grades, the tractor can be driven up the slope and the blade dropped down for back-dragging. It may also be used to push dirt or snow on pavement or other smooth surfaces.

ANGLING DOZER BLADE

The dozer blade can be hydraulically angled approximately 30° to the right or left by operating the proper tractor remote cylinder lever. In the angled position, the dozer blade can be used for backfilling trenches, side-casting into ditches, levelling and grading.

A dual relief valve is incorporated to protect the hydraulic angling system when the blade is overloaded. (This valve will bypass the hydraulic fluid and diminish the degrees that the blade was initially angled.)

! Important: To avoid damage to tractor or blade, the hydraulic system must be hooked up properly including line to hydraulic tank drain.

BLADE DEPTH

Gauge the depth of cut to push the most material possible without losing speed through spinning the wheels or slowing the tractor engine. Do this by setting the depth shoes, and by regulating the depth for the blade height with the lifting cylinder operating lever.

The distance the material is pushed should be kept to a minimum. Dig and cut the material downgrade whenever possible.

DEPTH/SKID SHOES

Soft uneven ground

- Skid shoe low
- Blade high

Hard even ground

- Skid shoe high
- Blade low

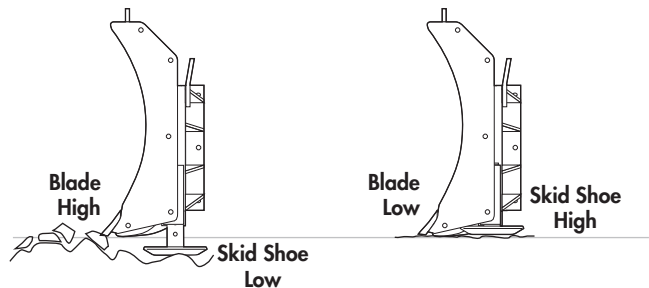

PRE-OPERATION CHECKLIST

Efficient and safe operation of the Dozer Blade requires that each operator reads and understands the operating procedures and all related safety procedures outlined in this manual.

Before Using for the FIRST Time

- Lubricate all points
- Torque all hardware to correct setting
- Check hardware torque & hydraulics after the first 2 hrs & again after 10 hrs.

Before Using EVERY Time

- Check:**
- If all points lubricated
 - All components attached securely
 - Condition of cutting edge
 - Depth/skid shoe wear
 - Hydraulics:
 - Tractor's oil reservoir
 - Condition of hoses, lines & fittings

Maintenance

MAINTENANCE SAFETY

1. Review the Operator's Manual and all safety items before working with, maintaining or operating the machine.
2. Lower machine to ground, stop the tractor engine, place all controls in neutral, set park brake and remove ignition key before servicing, adjusting or repairing.
3. Clear the area of bystanders, especially children when carrying out any maintenance and repairs or making adjustments.
4. Place safety stands or large blocks under the frame before removing tires or working beneath the machine.
5. Be careful when working around or maintaining a high-pressure hydraulic system. Wear proper eye and hand protection when searching for a high pressure hydraulic leak. Use a piece of wood or cardboard as a backstop when searching for a pin hole leak in a hose or a fitting.
6. Always relieve pressure before disconnecting or working on hydraulic system.

LUBRICANTS

1. Grease: Use an SAE multi-purpose grease with extreme pressure (EP) performance. Also acceptable is an SAE multi-purpose lithium base grease.
2. Storing Lubricants: Your machine can operate at top efficiency only if clean lubricants are used. Use clean containers to handle all lubricants. Store them in an area protected from dust, moisture and other contaminants.

GREASING

1. Use only a hand-held grease gun for all greasing.
2. Wipe grease fitting with a clean cloth before greasing, to avoid injecting dirt.
3. Replace and repair broken fittings immediately.
4. If fittings will not take grease, remove and clean thoroughly. Also clean lubricant passageway. Replace fitting if necessary.
5. Inject grease until you see grease being expelled from the pin or bushing areas.

LUBE AFTER EVERY 8 HRS.

Items to Grease	Qty.
Angle Cylinder Pins	2 per cylinder
Lift Cylinder Pins	2 per cylinder
Tilt Cylinder Pins	2 per cylinder
Blade Pivot Pin	1 on left side
Tilt Ring	2 per side
Tilt Bell Plate	2 per side
Tilt Bell Bushing	1 per side
Side Bracket Pins	1 per side
Main Pivot Pins	1 per side

Spray Lubricant	Qty.
D-lock® components	2 units - inside

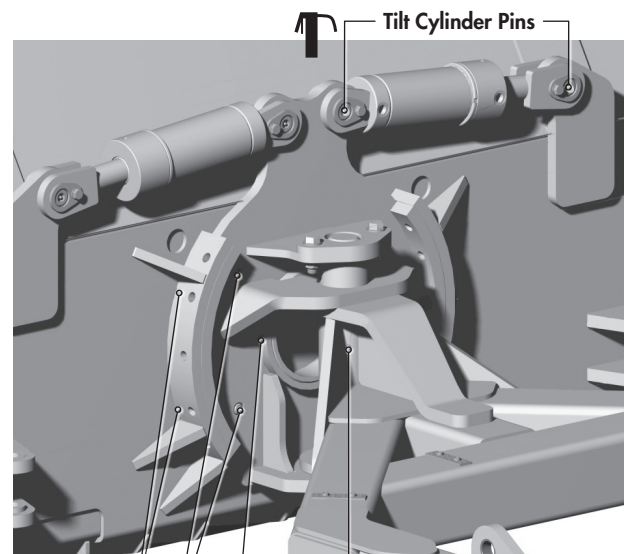

Tilt Ring
Tilt Bell Plate
Tilt Bell Bushing
(Typical both sides)

Blade Pivot Pin

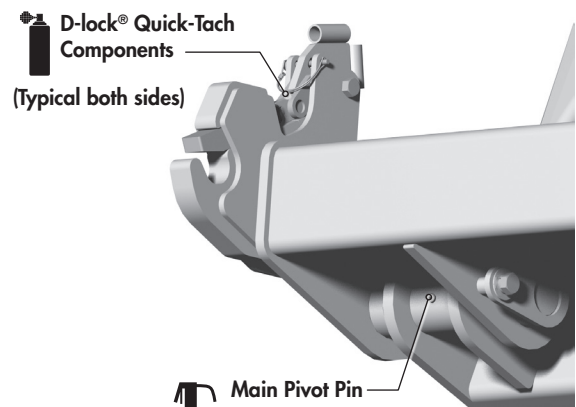

Main Pivot Pin
(Typical both sides)

Maintenance

HYDRAULIC SAFETY

1. Always place all tractor hydraulic controls in neutral before dismounting.
2. Make sure that all components in the hydraulic system are kept in good condition and are clean.
3. Replace any worn, cut, abraded, flattened or crimped hoses and metal lines.
4. Do not attempt any makeshift repairs to the hydraulic lines, fittings or hoses by using tape, clamps or cement. The hydraulic system operates under extremely high pressure. Such repairs will fail suddenly and create a hazardous and unsafe condition.
5. Wear proper hand and eye protection when searching for a high pressure hydraulic leak. Use a piece of wood or cardboard as a backstop instead of hands to isolate and identify a leak.
6. If injured by a concentrated high-pressure stream of hydraulic fluid, seek medical attention immediately. Serious infection or toxic reaction can develop from hydraulic fluid piercing the skin surface.
7. Before applying pressure to the system, make sure all components are tight and that lines, hoses and couplings are not damaged.

Think SAFETY! Work SAFELY!

CHECK HARDWARE TORQUE

Important: Check torque on all hardware periodically. Check after first 2, 10, 40, then every 200 hours.

TORQUE



all hardware

- Torque values listed are for general use only. If a different torque value or tightening procedure is specified for a specific application, do not use these values.
- Refer to the "Parts" section for proper grade and length of bolts for replacement parts.
- Do not replace locknuts with nuts and lock washers. Replace all parts with original, specified parts only.
- Dry values shown mean the bolt/nut is plain or zinc plated without any lubrication.

Unless otherwise stated:



Hardware - Hex, GR5 UNC (imperial) or P8.8 (metric)
Hoses - 3/8, ends come with 3/4 JIC female swivel.

HARDWARE TORQUE SETTINGS

The tables below give correct torque values for various bolts and capscrews. Tighten all bolts to values in charts unless otherwise noted. Check tightness of bolts periodically, using torque charts as a guide. Replace hardware with the same strength (Grade/Class) bolt.

IMPERIAL TORQUE SPECIFICATIONS

(based on "Zinc Plated" values)



SAE-5



SAE-8

Size	Grade 5	Grade 8
	lb.ft (N.m)	lb.ft (N.m)
1/4"	7 (10)	10 (14)
5/16"	15 (20)	20 (28)
3/8"	25 (35)	35 (50)
7/16"	40 (55)	60 (80)
1/2"	65 (90)	90 (120)
9/16"	90 (125)	130 (175)
5/8"	130 (175)	180 (245)
3/4"	230 (310)	320 (435)
7/8"	365 (495)	515 (700)
1"	550 (745)	770 (1050)
1-1/8"	675 (915)	1095 (1485)
1-1/4"	950 (1290)	1545 (2095)
1-3/8"	1250 (1695)	2025 (2745)
1-1/2"	1650 (2245)	2690 (3645)

METRIC TORQUE SPECIFICATIONS

(based on "Zinc Plated" values)



8.8



10.9

Size	Class 8.8	Class 10.9
	lb.ft (N.m)	lb.ft (N.m)
M6	7 (10)	10 (14)
M8	16 (22)	23 (31)
M10	30 (42)	45 (60)
M12	55 (75)	80 (108)
M14	90 (120)	125 (170)
M16	135 (185)	195 (265)
M18	190 (255)	270 (365)
M20	265 (360)	380 (515)
M22	365 (495)	520 (705)
M24	460 (625)	660 (895)
M27	675 (915)	970 (1315)
M30	915 (1240)	1310 (1780)
M33	1250 (1695)	1785 (2420)
M36	1600 (2175)	2290 (3110)

HYDRAULIC FITTING TORQUE

Size	lb.ft (N.m)
3/4	75 (100)
7/8	90 (122)

Maintenance

HYDRAULIC CYLINDER REPAIR

PREPARATION

When cylinder repair is required, clean off unit, disconnect hoses and plug ports before removing cylinder.

When removed, open the cylinder ports and drain the cylinder's hydraulic fluid.

Examine the type of cylinder. Make sure you have the correct tools for the job.

You may require the following tools:

- Proper **Seal Kit**
- Rubber Mallet
- Screwdriver
- Punch
- Pliers
- Emery cloth
- Torque Wrench

Types of Cylinders (Wire Ring / Threaded Head)

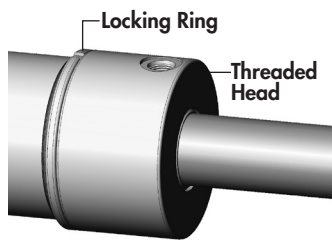
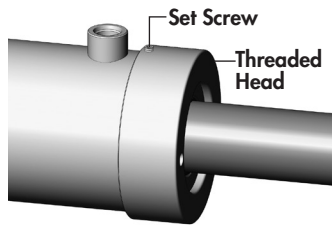
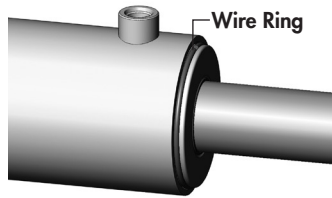

REPAIRING A WIRE RING CYLINDER

1. Retract the rod assembly.
2. Remove the external steel wire ring.

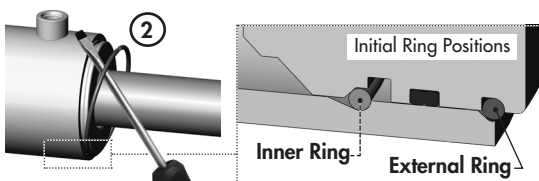

3. Remove any dirt that may have accumulated on the cylinder head.

4. Using the mallet and punch, push the head into the cylinder tube until the internal tube groove is fully exposed. This will also move the internal wire ring into its removal position.



5. Take the plastic removal ring from the seal kit:
 - a) Straighten the ring and remove any kinks or excessive curl to make installation easier and prevent it from falling out.
 - b) Insert the removal ring into the internal groove with the feathered end pointing into the tube.

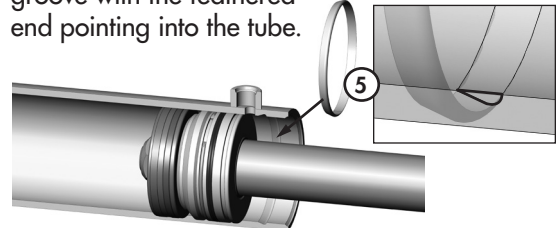

- c) Use a screwdriver or a finger to hold one end of the ring in the groove while fitting the other end of the ring into the groove. The tips should snap in together. Ensure it is secure and fully seated before the next step.

IMPORTANT: It is important to ensure the removal ring is completely in the groove before pulling the rod out. If the ring sticks out it will get stuck between the head and tube.

6. a) Extend the rod to pull head out of tube. If the rod does not pull out easily, push the head back in and ensure the ring is properly in the groove. Replace ring if necessary.

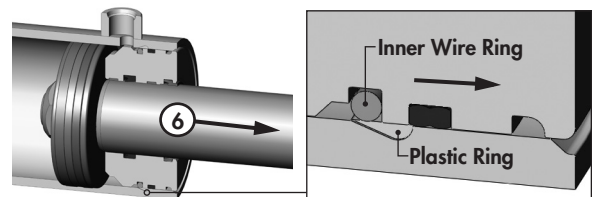

Note: Excessive force will not overcome a jammed ring and could damage the cylinder.

- b) Completely remove rod and head from tube.

7. Remove plastic removal ring from the cylinder tube.

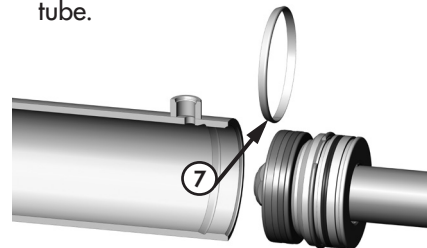

Maintenance

8. Remove locknut, piston and head from rod.

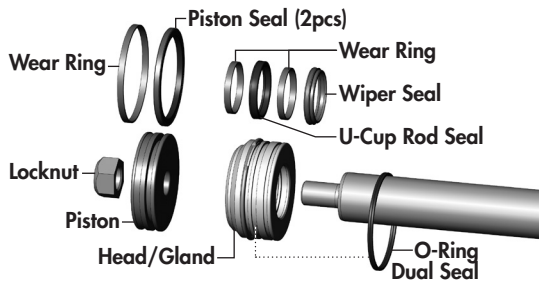

9. a) Inspect and replace all of the seals with new components.
 b) Inspect the inside of the cylinder barrel, piston, rod and other polished parts for burrs and scratches. Smooth areas as needed with an emery cloth.
 c) During re-assembly of head/gland assembly, leave the outer O-Ring Dual Seal loose on the rod to re-install at a later step.

10. Replace piston and torque the locknut to required value. (Refer to chart below)

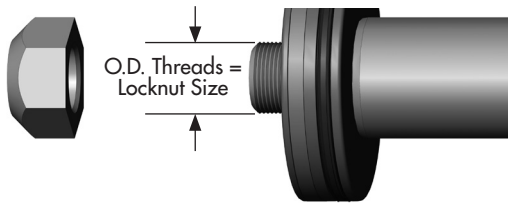

LOCKNUT SIZE (PISTON)	TORQUE VALUE
3/8 - 24 UNF	25-30 lb.ft (35-42 N.m)
1/2 - 20 UNF	40-60 lb.ft (55-80 N.m)
5/8 - 18 UNF	95-105 lb.ft (130-140 N.m)
3/4 - 16 UNF	175-225 lb.ft (240-305 N.m)
7/8 - 14 UNF	200-275 lb.ft (270-370 N.m)
1 - 14 UNF	300-380 lb.ft (405-515 N.m)
1 1/8 - 12 UNF	400-500 lb.ft (540-675 N.m)
1 1/4 - 12 UNF	500-600 lb.ft (675-810 N.m)
1 1/2 - 12 UNF	700-800 lb.ft (950-1085 N.m)
1 3/4 - 12 UNF	800-900 lb.ft (1085-1220 N.m)

11. a) Install the supplied band clamp to compress the inner wire ring on the head/gland assembly so it will fit into the tube.
Note: Make sure the cam of the band clamp is not overtop of the gap in the ring.

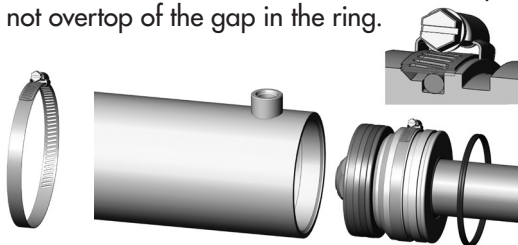

b) Tighten the band clamp to ensure the wire ring is fully seated. Then, loosen the clamp approx. 1/2 a turn to allow band clamp to slide during final assembly.

12. Lubricate the cylinder tube and piston seals.

13. Insert the piston into the tube. Tap the cylinder head into the tube until the clamp slides over and the inner wire ring is inside the tube.

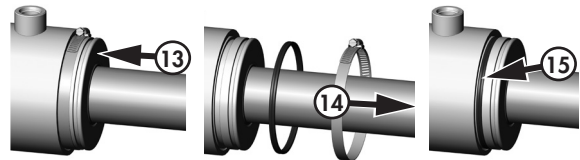

14. Loosen the clamp and remove.

15. Install the O-Ring Dual seal.

16. Tap the head the rest of the way until the end is flush with the tube.

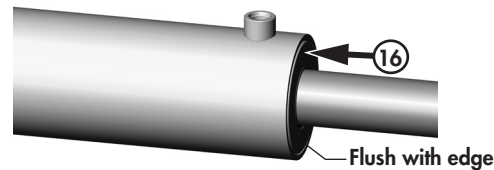

IMPORTANT: The head/gland must be inserted until it is flush with the tube to allow the inner wire ring to snap into its seated position in the internal cylinder groove. Failure to insert the head flush as shown will result in the head and rod assembly coming out of the tube when pressure is applied to the cylinder.

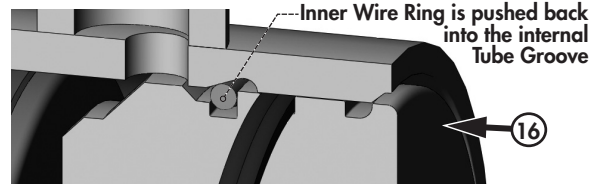

17. Pull the rod out to expose the external wire ring groove in cylinder head, and then install the external ring.

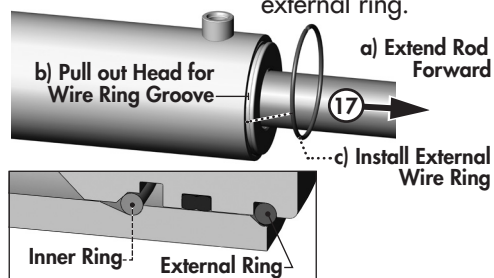

18. Before using the cylinder, ensure that you double check your work.

Maintenance

REPAIRING A THREADED HEAD CYLINDER

SET SCREW

STYLE

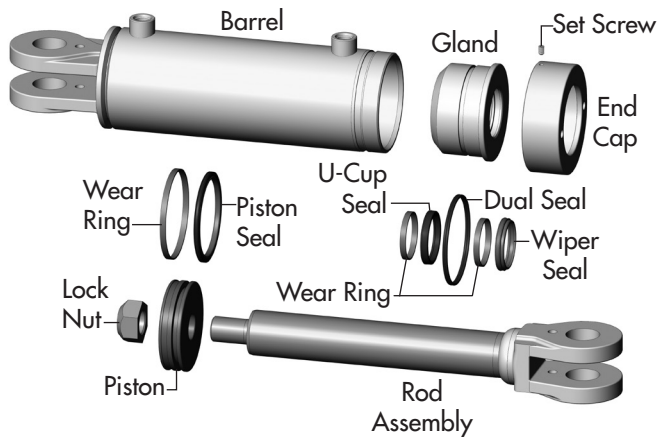

DISASSEMBLY

1. Loosen Set Screw and turn off end cap.
2. Carefully remove piston/rod/gland assemblies.
3. Disassemble the piston from the rod assembly by removing lock nut.

NOTE: *DO NOT* clamp rod by chrome surface.

4. Slide off gland assembly & end cap.
5. Remove seals and inspect all parts for damage.
6. Install new seals and replace damaged parts with new components.
7. Inspect the inside of the cylinder barrel, piston, rod and other polished parts for burrs and scratches. Smooth areas as needed with an emery cloth.

REASSEMBLY

1. Reinstall rod through end cap & gland assembly.
2. Secure piston to rod with lock nut. Torque lock nut to proper value (refer to chart on previous page for proper torque value).
3. Lube inside of barrel, piston seals, and gland seals with hydraulic oil.
4. With cylinder body held gently in a vise, insert piston, gland, end cap and rod combination using a slight rocking motion.
5. Apply loctite anti-seize before installing cylinder end cap.
6. Torque cylinder end cap to 440 lb.ft (600 N.m).
7. Tighten Set Screw on end cap to 6 lb.ft (8 N.m).

REPAIRING A THREADED HEAD CYLINDER

Locking Ring Style

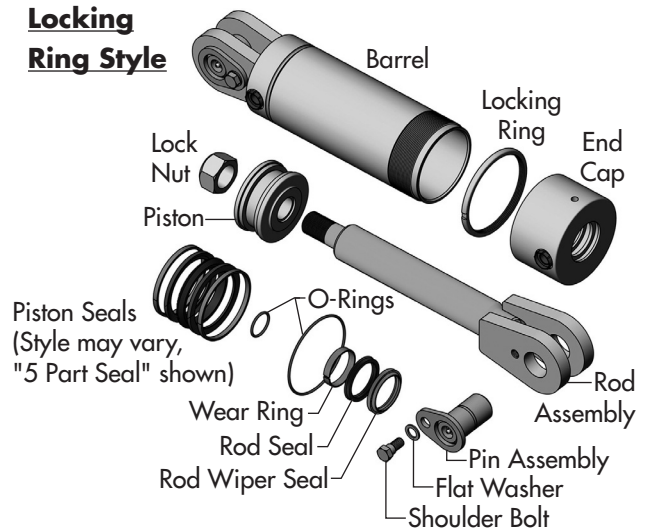

DISASSEMBLY

1. Loosen Locking Ring and turn off end cap.
2. Carefully remove piston, rod and end cap.
3. Disassemble the piston from the rod assembly by removing lock nut.

NOTE: *DO NOT* clamp rod by chrome surface.

4. Slide off end cap.
5. Remove seals and inspect all parts for damage.
6. Install new seals and replace damaged parts with new components.
7. Inspect the inside of the cylinder barrel, piston, rod and other polished parts for burrs and scratches. Smooth areas as needed with an emery cloth.

REASSEMBLY

1. Reinstall rod through end cap.
2. Secure piston to rod with lock nut. Torque lock nut to proper value (refer to chart on previous page for proper torque value).
3. Thread lock ring fully onto barrel.
4. Lube inside of barrel and piston seals with hydraulic oil.
5. With cylinder body held gently in a vise, insert piston, end cap and rod combination using a slight rocking motion.
6. Turn end cap fully against lock ring then back off end cap to align ports.
7. Tighten Locking Ring against end cap using a punch and hammer.

Maintenance

SAFETY DECALS

1. Keep safety decals and signs clean and legible at all times.
2. Replace safety decals and signs that are missing or have become illegible.
3. Replaced parts that displayed a safety sign should also display the current sign.
4. Safety decals or signs are available from your Dealer Parts Department. Safety decals will be available upon request.

How to Install Safety Decals:

- Be sure that the installation area is clean and dry.
- Decide on the exact position before you remove the backing paper.
- Remove the smallest portion of the split backing paper.
- Align the decal over the specified area and carefully press the small portion with the exposed sticky backing in place.
- Slowly peel back the remaining paper and carefully smooth the remaining portion of the decal in place.

REPLACEMENT DECALS

Decals, especially safety and reflective, should be replaced when they become damaged or worn. Contact your dealer.

Safety Decals

143038	Mounting Decal, Use Handle	2
142546	Remove Jack Decal	2
142386	Warning Decal, Falling Blade	2
143240	Tow Cable Routing (Optional)	2

Reflective Decals

142556	Red Reflector, 9" lg	2
142279	Amber Reflector, 3-1/4" lg	1

Product Decals

142008	Degelman Logo, 25-3/4" lg	2
143209	7900 Blade Decal	1

TILT LOCKOUT KIT OPTION

1. Keep safety decals and signs clean and legible at all times.
2. Replace safety decals and signs that are missing or have become illegible.

Note: Tilt Lockout Kit may be used *without* Angle Lockout Kit.

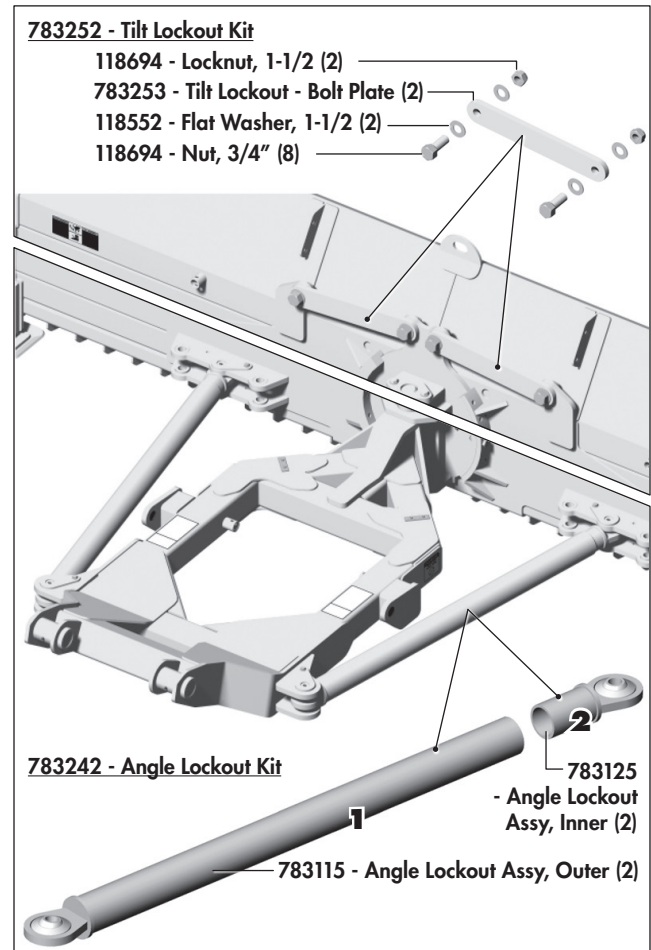

ANGLE LOCKOUT KIT OPTION

⚠ IMPORTANT: Tilt Lockout Kit **MUST** also be purchased and installed if using the Angle Lockout Kit to avoid equipment damage.

1. Install components (1 & 2) loosely.
2. Ensure blade is straight.
3. Measure and mark positions for welding.
4. Tack weld into place (if desired).
5. Remove and weld fully.
6. Clean and paint.
7. Reinstall into place.

Transport & Storage

TRANSPORT SAFETY

- Read and understand ALL the information in the Operator's Manual regarding procedures and SAFETY when operating the machine in the field/yard or on the road.
- Check with local authorities regarding machine transport on public roads. Obey all applicable laws and regulations.
- Always travel at a safe speed. Use caution when making corners or meeting traffic.
- Make sure the SMV (Slow Moving Vehicle) emblem and all the lights and reflectors that are required by the local highway and transport authorities are in place, are clean and can be seen clearly by all overtaking and oncoming traffic.
- Keep to the right and yield the right-of-way to allow faster traffic to pass. Drive on the shoulder, if permitted by law.
- Always use hazard warning flashers on tractor when transporting, unless prohibited by law.

TRANSPORTING

Follow this procedure when preparing to transport:

1. Clear the area of bystanders, especially small children, before converting into transport configuration.
2. Operate the lift hydraulics to raise the blade fully and install a certified safety chain to secure it.
3. Clean the SMV sign, lights and reflectors.
4. Maintain a safe speed. Slow down when cornering and on rough roads.
5. Slow down and pull off to the side of the road when meeting other traffic.
6. Use hazard flashers on tractor unless prohibited by law.

STORAGE SAFETY

- Store unit in an area away from human activity.
- Do not permit children to play near the stored unit.

STORAGE

After the season's use, completely inspect all major systems of the machine. Repair or replace any worn or damaged components to prevent unnecessary down time at the beginning of next season.

Since the unit can be used in extremely adverse conditions during the season, the machine should be carefully prepared for storage to ensure that all dirt, mud, debris and moisture has been removed.

Follow this procedure when preparing to store:

1. Wash the entire machine thoroughly using a water hose or pressure washer to remove all dirt, mud, debris or residue.
2. Inspect all parts to see if anything has become entangled in them. Remove the entangled material.
3. Lubricate all grease fittings to remove any moisture.
4. Inspect all hydraulic hoses, fittings, lines and couplers. Tighten any loose fittings. Replace any hose that is badly cut, nicked or abraded or is separating from the crimped end of the fitting.
5. Touch up all paint nicks and scratches to prevent rusting.
6. Oil the exposed rams on the hydraulic cylinder to prevent rusting.
7. Select an area that is dry, level and free of debris.

Troubleshooting

GENERAL TROUBLESHOOTING

SYMPTOM	PROBLEM	SOLUTION
Dozer Falls Down In Transport.	Lift cylinder hydraulic circuit not connected correctly.	Trace your hoses from front to back of tractor, making sure angle circuit connected to rear relief valve, not lift circuit.
Dozer Angle Won't Hold.	Excessive loading of dozer.	Reduce amount of material pushing. Equipped with safety angle relief valve, pressure exceeded.
	Excessive impact on dozer.	Reduce speed of impact on high load. Equipped with safety angle relief valve, pressure exceeded.
Cutting Edge Wearing Excessively In Center Of The Dozer.	High downward force of dozer in contact with crown of road.	Adjust skid shoes to prevent cutting edge contact with road crown.
		Change operation of the dozer to prevent running on crown of road.
Cutting edge wearing excessively at ends of dozer.	High downward force on ends of dozer.	Run dozer tilt circuit in float to contour to ground.
		Change operation to prevent this type of contact.
		Adjust skid shoes to prevent contact.
Hydraulic angle circuit hoses pop out of valve stack.	Relief valve tank drain hose not connected properly.	Ensure hydraulic tank drain hose goes directly to tank with no internal pressure.
Cannot open D-lock linkage when attached to tractor.	Dozer not raised off the ground.	Raising the dozer off the ground removes pressure from D-lock. Lift dozer off ground.
	Foreign material in linkage.	Clean linkage to allow movement.
Difficult or cannot turn skid shoe jack handle.	Too much pressure on jack.	Raise dozer off ground to adjust skid shoe depth.
Breaking cutting edge bolts.	Cutting edge bolts not properly torqued. Torque 5/8" Gr.8 bolts to 225 lb-ft Torque 3/4" Gr.8 bolts to 400 lb-ft	Under torqued bolts allows impact to break bolts.
		Over torqued bolts can fail from too much tension loading.
Dozer won't angle or will not come back from full angle.	Hoses not properly coupled in valve stack.	Remove and re-install hoses into valve stack.
	Angle relief valve return to tank line not properly installed.	Change return to tank line so that no internal pressure, run direct to tank.
Dozer not following ground contour.	Tilt circuit not allowed to float.	Float hydraulic tilt circuit.
D-lock will not stay in open position, falls closed.	Clip pin not being used.	Use clip pin to hold open.
Cannot align front bracket roller with main frame front quick attach lug.	Heights are not aligned.	Use dozer hydraulic lift circuit to adjust main frame front lug height.
		Use jacks on side on main frame to adjust height.

Blade Attachments

OPTIONAL BLADE ATTACHMENTS

- 790216 - 20 ft Silage Extension
- 790200 - 18 ft
- 790211 - 16 ft (shown)
- 790221 - 14 ft
- 790226 - 12 ft

- 790006 - Side Plate, High Volume (2)
- 790350 - Extension, 1' (2)

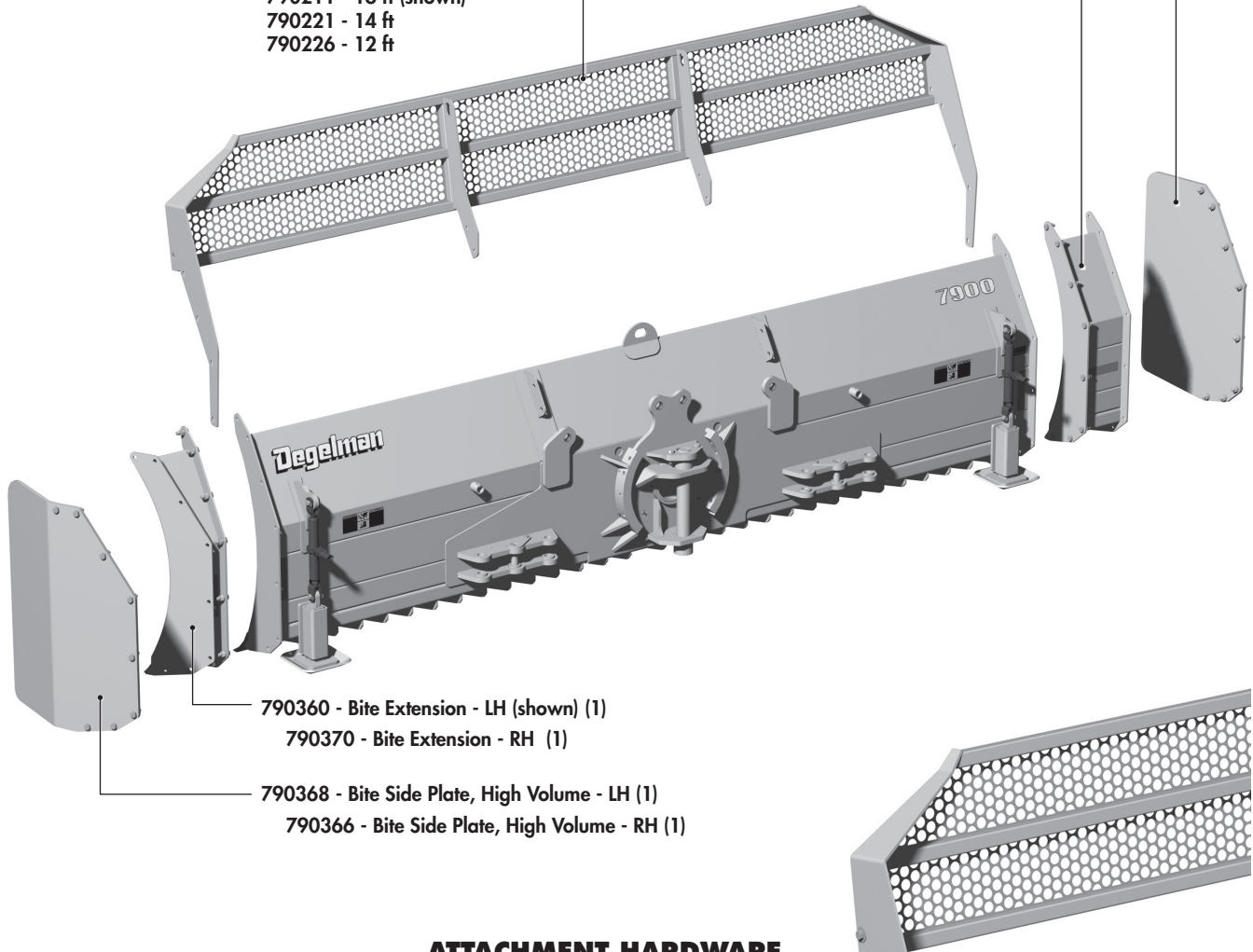

- 790360 - Bite Extension - LH (shown) (1)
- 790370 - Bite Extension - RH (1)
- 790368 - Bite Side Plate, High Volume - LH (1)
- 790366 - Bite Side Plate, High Volume - RH (1)

ATTACHMENT HARDWARE

- 118410 - Nut, 3/4" (14)
 - 118509 - Lock Washer, 3/4" (14)
 - 118516 - Flat Washer, 3/4" (28)
 - 118047 - Bolt, 3/4" x 2-1/2" (14)
- Silage Extension Hardware

- 118043 - Bolt, 3/4" x 2" (8)
 - 118509 - Lock Washer, 3/4" (8)
 - 118410 - Nut, 3/4" (8)
- Extension Hardware

- 118410 - Nut, 3/4" (8)
 - 118509 - Lock Washer, 3/4" (8)
 - 118743 - Bolt, 3/4" x 2-1/4" (8)
- Side Plate Hardware

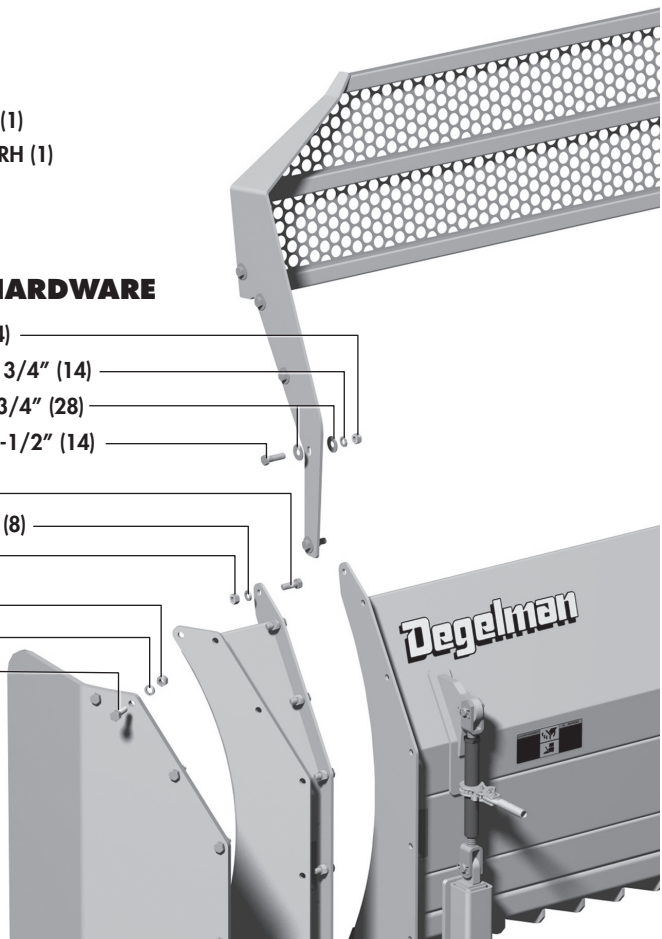

7900 Blade Components

7900 BLADE ASSEMBLY

- 790040 - 20 ft
- 790000 - 18 ft
- 790050 - 16 ft (shown)
- 790060 - 14 ft
- 790070 - 12 ft

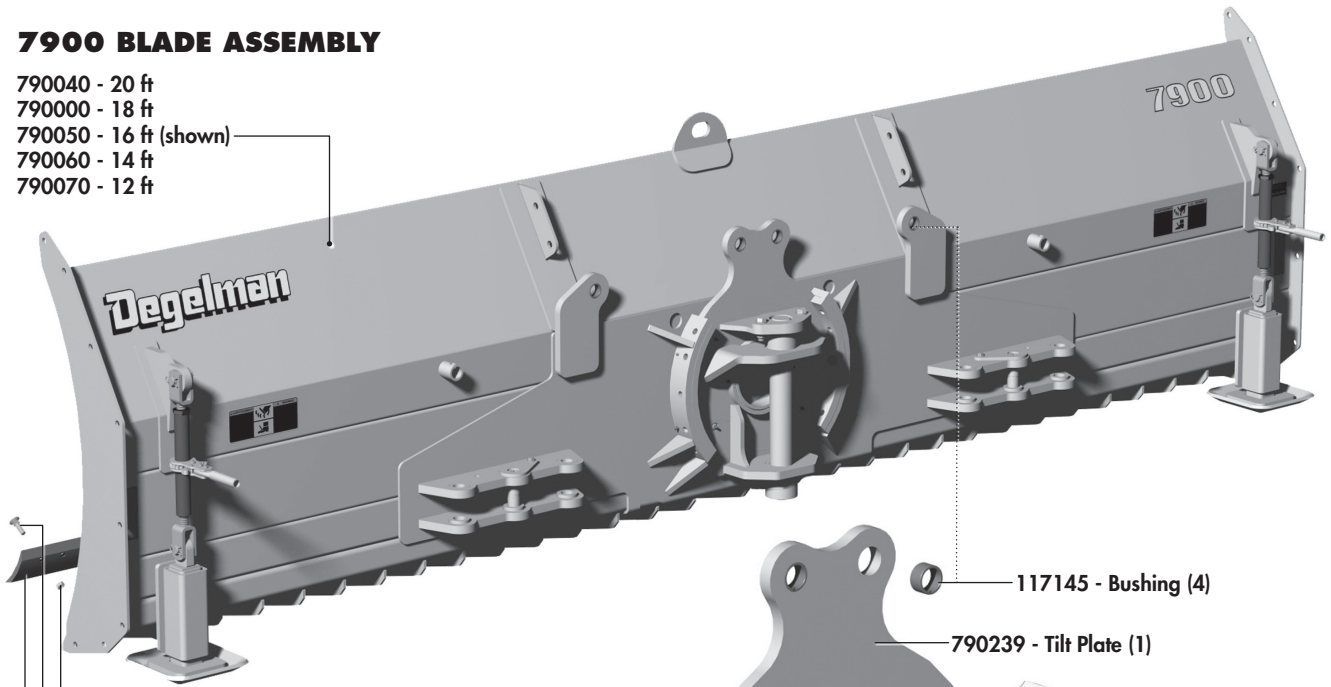

- 118422 - Lock Nut, 3/4" UNC GR5 (ar)
- 117435 - Scraper Bolt, 3/4" x 2-3/4" UNC GR8 (ar)
- 116114 - Cutting Edge, 3/4" x 8" x 6' (2)
- 116115 - Cutting Edge, 3/4" x 8" x 7' (2)
- 116116 - Cutting Edge, 3/4" x 8" x 8' (2)
- 116117 - Cutting Edge, 3/4" x 8" x 9' (2)
- 116118 - Cutting Edge, 3/4" x 8" x 10' (2)

Note: Some previous 7900 blades use the following 5/8" cutting edges & hardware.

- 118448 - Lock Nut, 5/8" - Unitorque (ar)
- 118204 - Plow Bolt, 5/8" x 2-1/4" (ar)
- 116206 - Cutting Edge, 5/8" x 6" x 6' (2)
- 116207 - Cutting Edge, 5/8" x 6" x 7' (2)
- 116208 - Cutting Edge, 5/8" x 6" x 8' (2)
- 116209 - Cutting Edge, 5/8" x 6" x 9' (2)
- 116210 - Cutting Edge, 5/8" x 6" x 10' (2)

- 118611 - Bolt, 1/2" x 2-1/4" (2)
- 118587 - Flat Washer, 1/2" SAE (2)
- 790022 - Angle Pin, 1-1/2" x 5-1/2" (2)
- 118587 - Flat Washer, 1/2" SAE (2)
- 118504 - Lock Washer, 1/2" (2)
- 118405 - Nut, 1/2" (2)

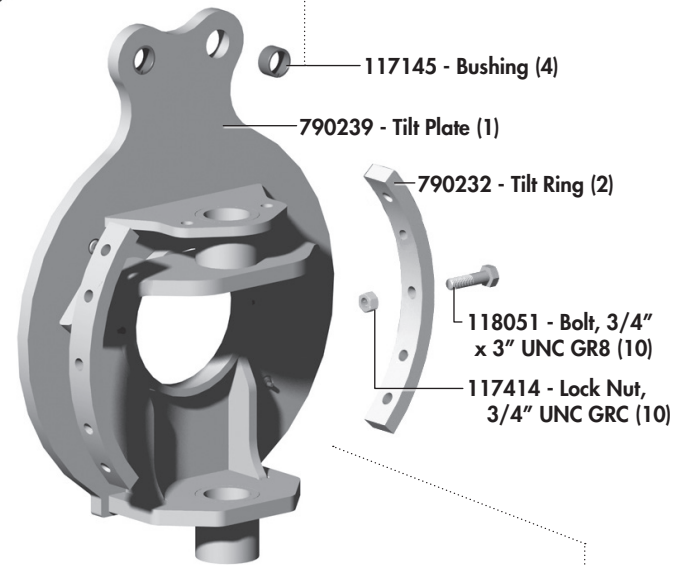

- 117145 - Bushing (4)
- 790239 - Tilt Plate (1)
- 790232 - Tilt Ring (2)
- 118051 - Bolt, 3/4" x 3" UNC GR8 (10)
- 117414 - Lock Nut, 3/4" UNC GRC (10)

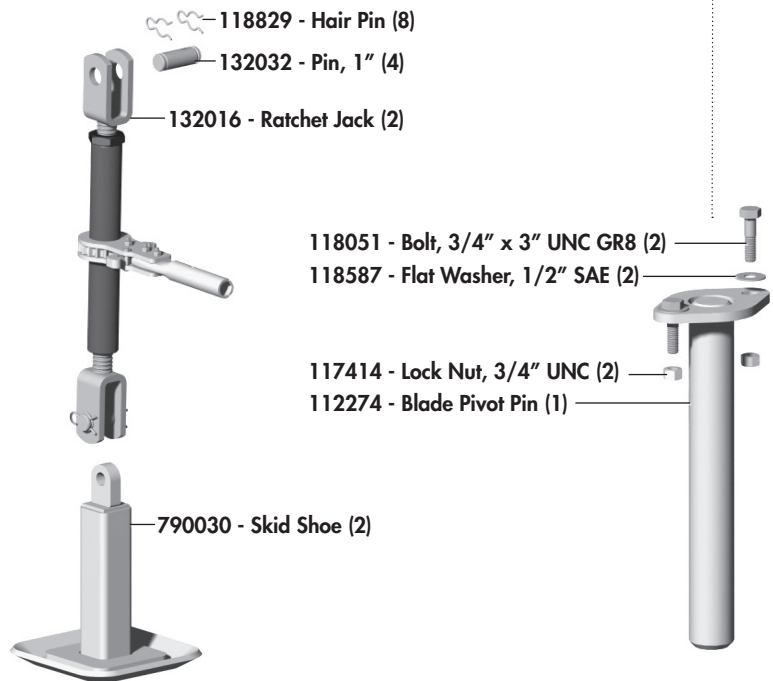

- 118829 - Hair Pin (8)
- 132032 - Pin, 1" (4)
- 132016 - Ratchet Jack (2)
- 118051 - Bolt, 3/4" x 3" UNC GR8 (2)
- 118587 - Flat Washer, 1/2" SAE (2)
- 117414 - Lock Nut, 3/4" UNC (2)
- 112274 - Blade Pivot Pin (1)
- 790030 - Skid Shoe (2)

Pivot & Main Frame - Case STX / NH TJ 275-500

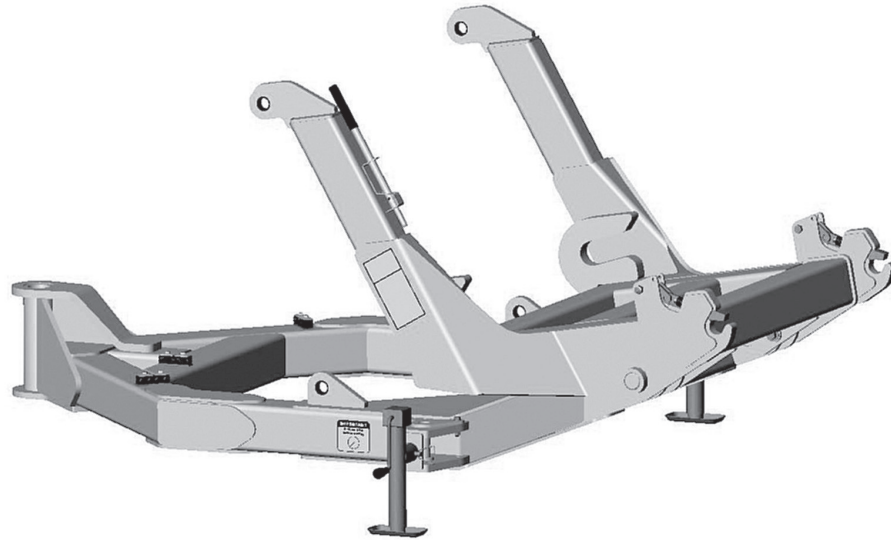

- 784115 - Main Frame Assembly (STX/TJ 275 325) (1)
- 784030 - Main Frame Assembly (STX/TJ 375-500) (1)

117145 - Bushing (2)

243374 - D-lock Handle (1)

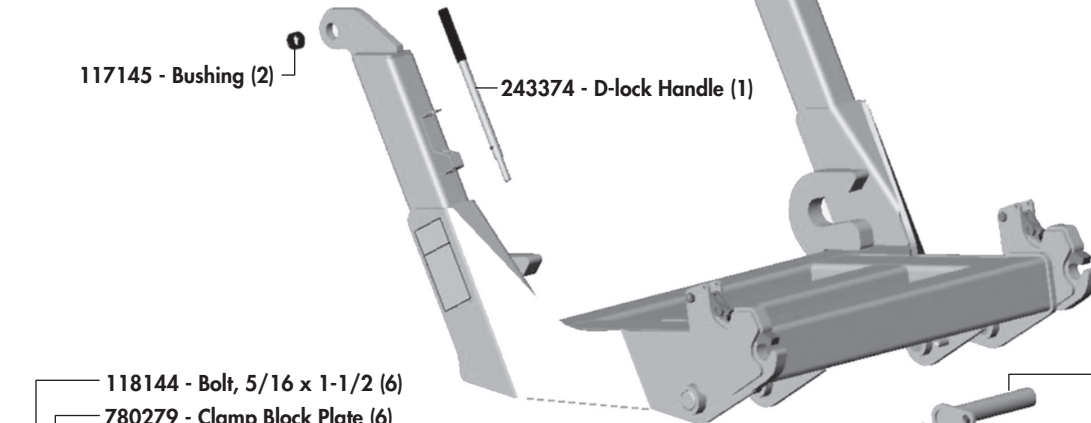

- 118144 - Bolt, 5/16 x 1-1/2 (6)
- 780279 - Clamp Block Plate (6)
- 780278 - Hose Clamp Block (6)

784081 - Pivot Pin, pivot/main (2)

- 118514 - Flat Washer, 5/8 F436 (2)
- 118508 - Lock Washer, 5/8 (2)
- 118645 - Bolt, 5/8 x 1-1/4 (2)

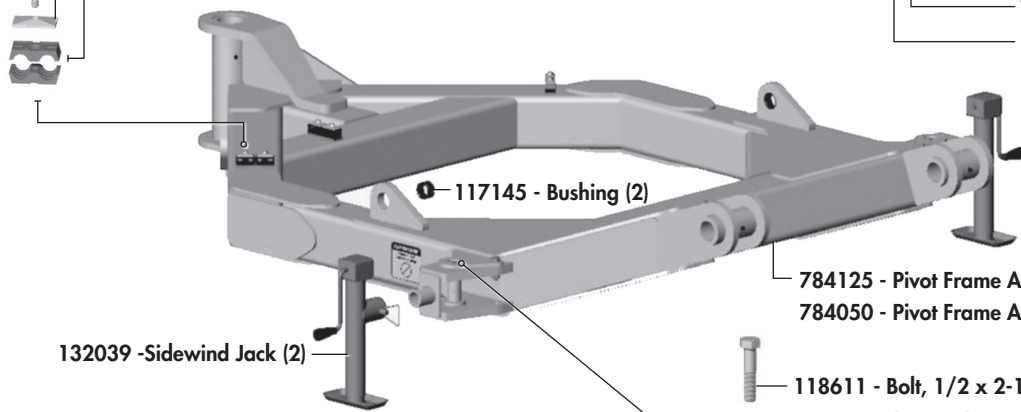

132039 - Sidewind Jack (2)

117145 - Bushing (2)

- 784125 - Pivot Frame Assembly (STX/TJ 275 325) (1)
- 784050 - Pivot Frame Assembly (STX/TJ 375-500) (1)

- 118611 - Bolt, 1/2 x 2-1/4 (2)
- 118587 - Flat Washer, 1/2 SAE F436 (4)



- 118504 - Lock Washer, 1/2 (2)
- 118405 - Nut, 1/2 (2)
- 790022 - Angle Pin, 1-1/2 x 5-1/2 (2)

Pivot & Main Frame - Case STX QuadTRAC 375-500

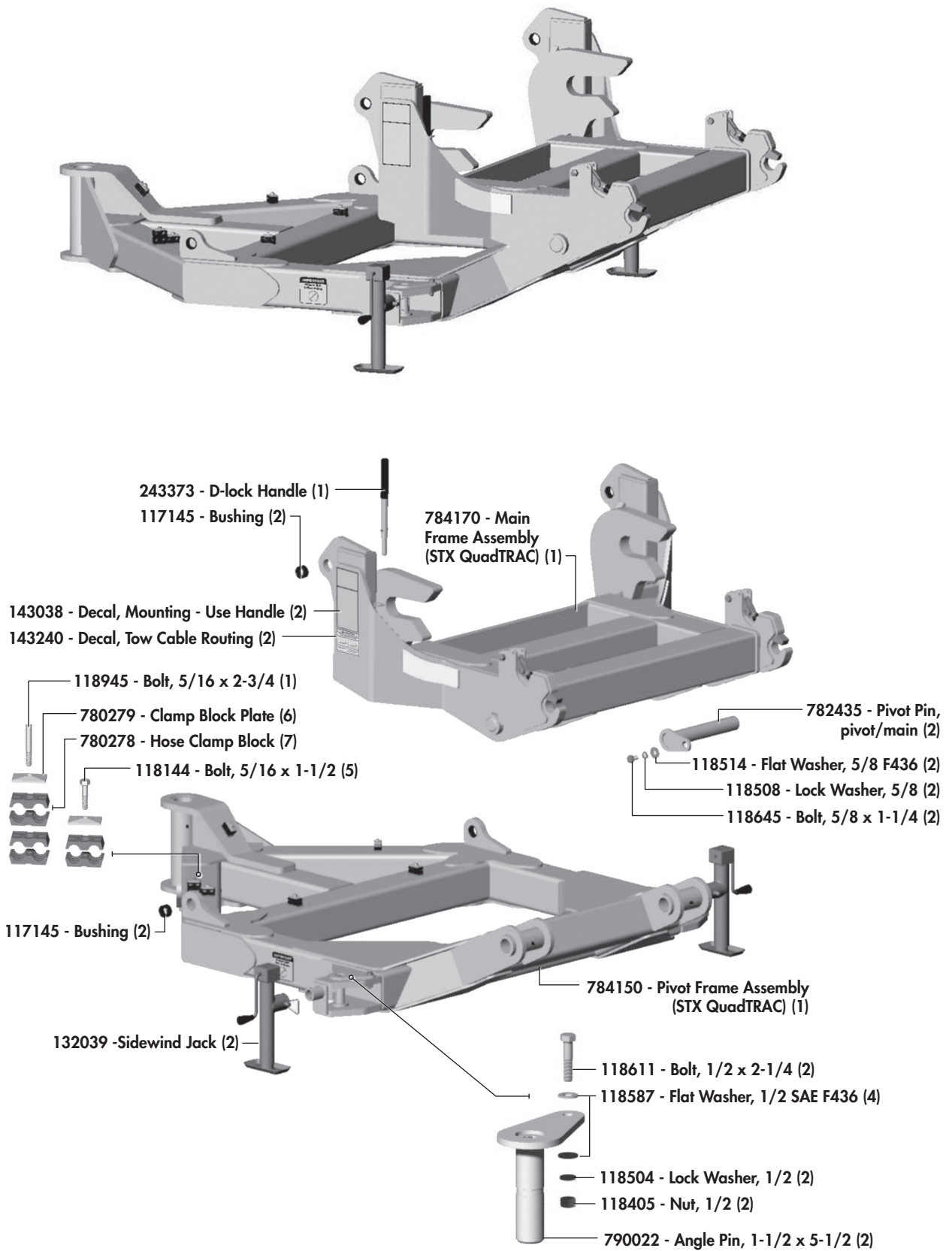

Mounting Brackets

CASE STX/NH TJ 275 325 - SIDE AND AXLE BRACKETS

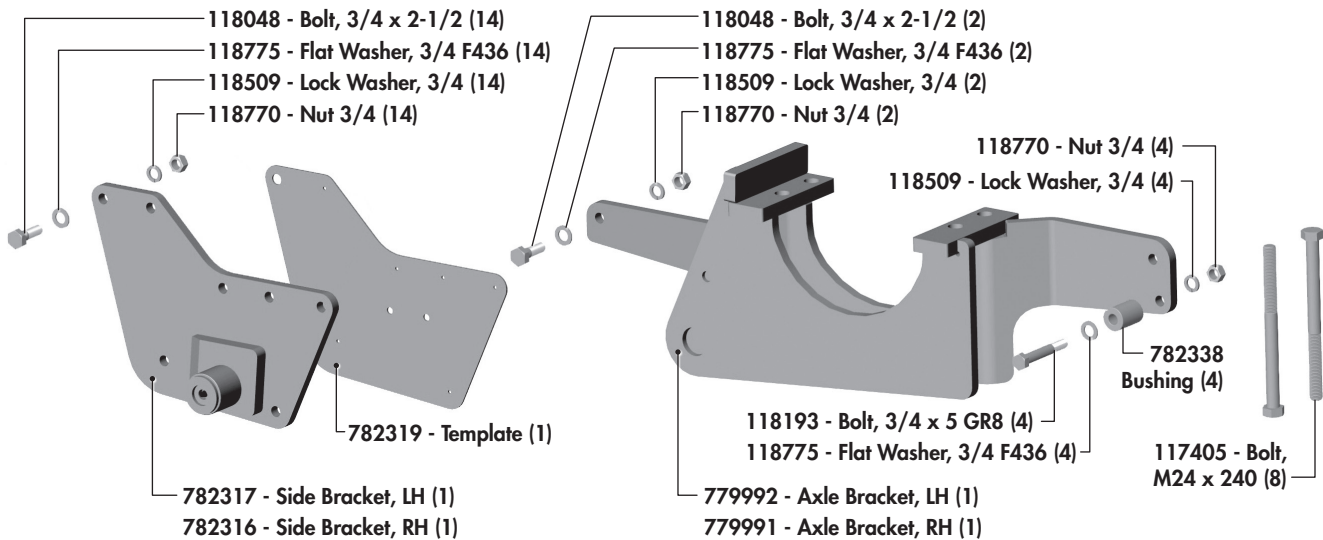

CASE STX/NH TJ 375-500 - SIDE AND AXLE BRACKETS

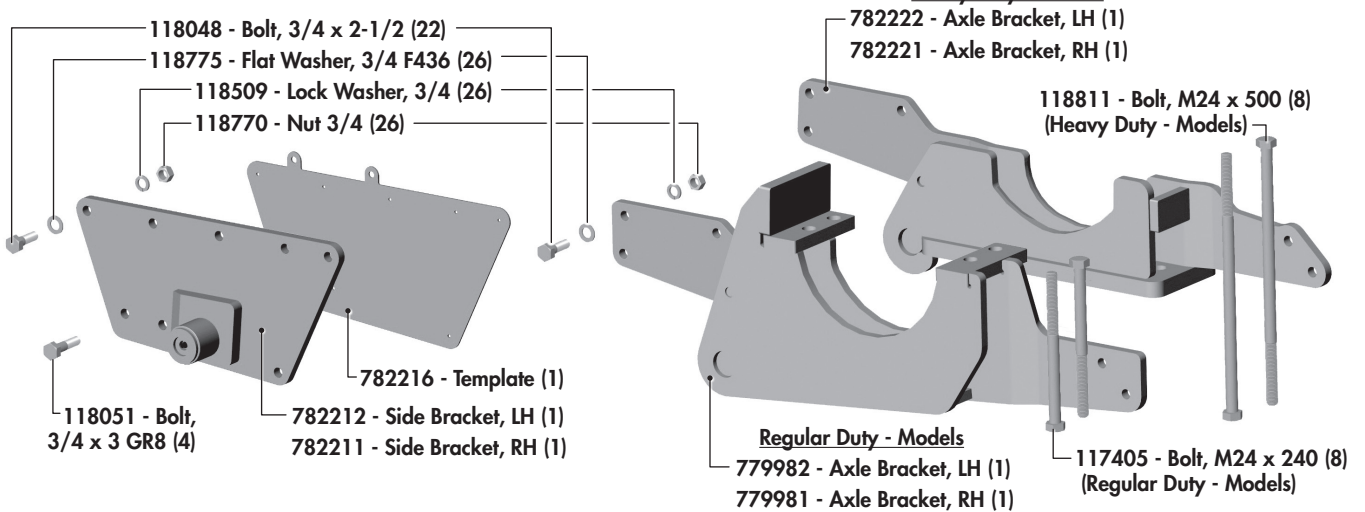

Note: STX/TJ 375 model tractors are available in either Regular or Heavy Duty. Please match the corresponding axle brackets & hardware. STX/TJ 425 models with 24 speed manual trans. use Regular Duty axle brackets. Powershift trans. models use Heavy Duty brackets. STX/TJ 440-500 model tractors use Heavy Duty axle brackets.

CASE STX QuadTRAC 375-500 - SIDE AND AXLE BRACKETS

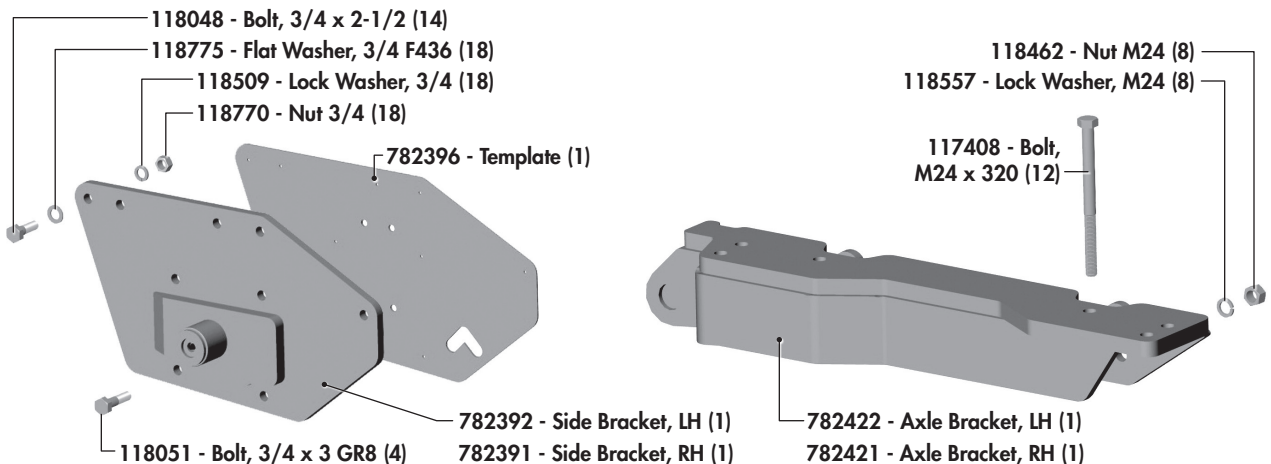

Hydraulic Brackets

COUPLER MOUNT BRACKET

NOTES:

For hydraulic bracket mounting location refer to the correct bracket installation section for your tractor model.

Refer to hydraulic section for relief valve installation and all hose and fitting descriptions and quantities.

- 118136 - Bolt, 3/8 x 1-1/2 (2)
- 118511 - Flat Washer, 3/8 (4)
- 118503 - Lock Washer, 3/8 (2)
- 118403 - Nut, 3/8 (2)
- 784108 - Hydraulic Coupler Mount Bracket (1)

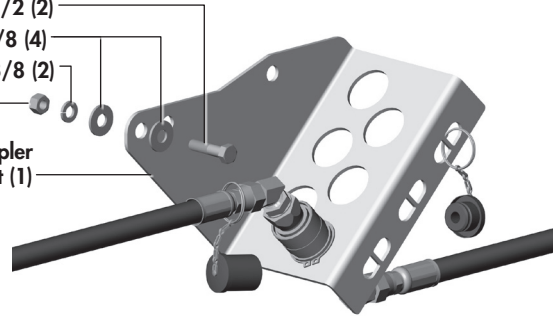

HOSE GUIDE BRACKETS - FRONT, AXLE & REAR (CASE STX QuadTRAC Models Only)

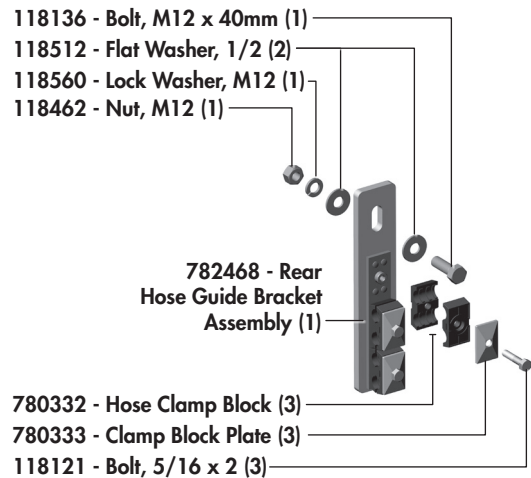
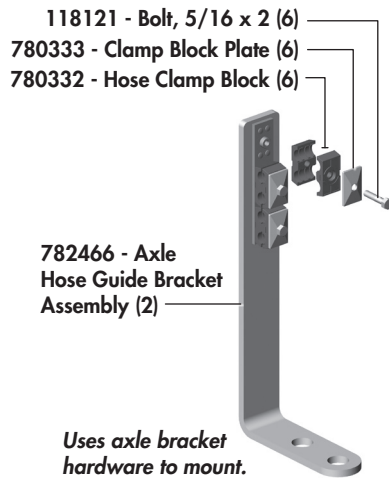
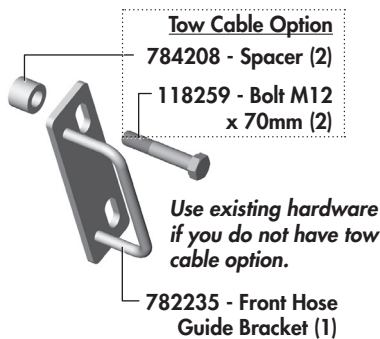

RADAR UNIT BRACKETS

Use existing tractor hardware and new supplied hardware to mount brackets.

CASE STX/NH TJ 275 325

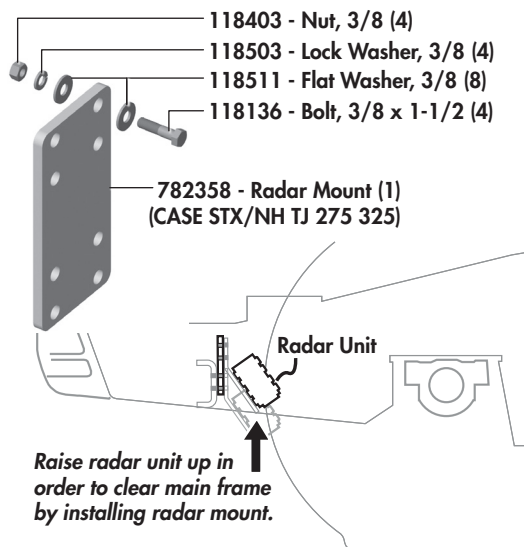

CASE STX/NH TJ 375-500 CASE STX QuadTRAC 375-500

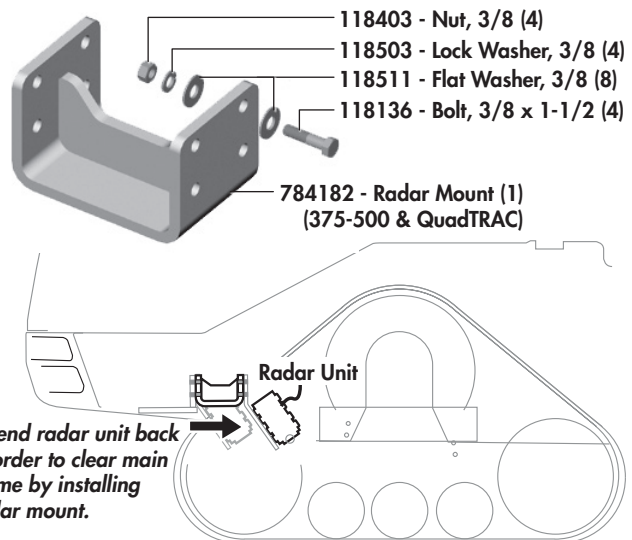

Bracket Installation

CASE STX/NH TJ 275 325 MODELS

- Existing Holes - Not Used
- Existing Holes - Used to attach template, hose guide, and hyd. coupler bracket.
- Holes to Drill - Used to attach side and axle brackets.

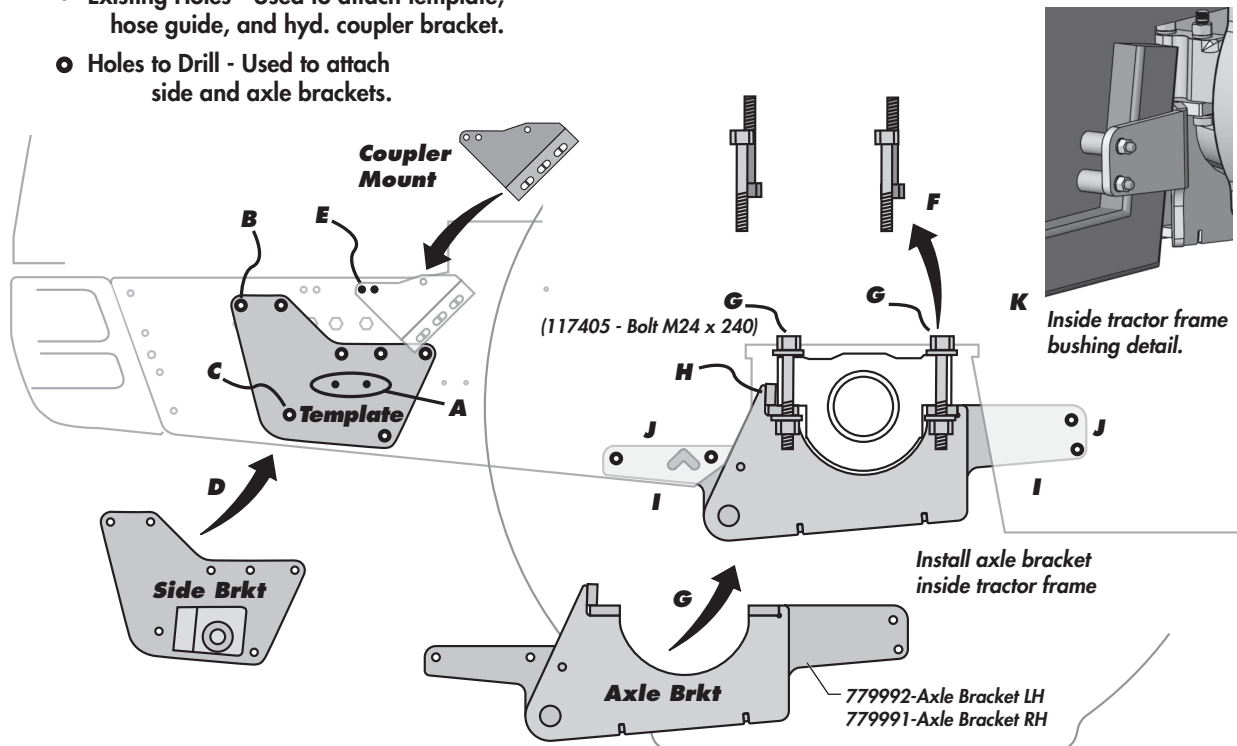

SIDE BRACKET INSTALLATION

- Remove the tractor's steps. Store or discard steps. Using the tractor step hardware, mount the template through the two holes in the center of the template.
- Make sure the large hole on the template (shown as "B" above) is aligned over the centre of the small hole on the frame. Ream that hole out to 13/16.
- Center punch the remaining six holes on template to scribe points. Remove template and drill out those six points to 13/16.
- Install side bracket with the supplied 3/4 x 2-1/2 bolts in all seven holes.
- Attach the hydraulic coupler mount bracket into the existing holes shown above using the hardware supplied.

AXLE BRACKET INSTALLATION

- Remove the existing M24 bolts (4), flat washers, & nuts holding the axle to the tractor frame.
PLEASE NOTE BOLT ORIENTATION.
All hardware, except bolts, will be reused.
- Install Degelman axle bracket loosely using the new supplied M24x240 bolts (4) and existing nuts and flat washers from Step F.
- Ensure front axle pad is positioned tight to front of casting. Tighten axle bracket hardware.
- Clamp axle bracket in place against inside of tractor frame. Use bushings on rear holes.
- Drill out the four holes to 13/16 from inside tractor frame using axle bracket as template.
- Install with the supplied 3/4 x 2-1/2 bolts in two places at front and 3/4 x 5 in two places at back with axle bracket bushings (see detail).

IMPORTANT-TORQUE



Torque all bolts properly!
Refer to maintenance section for torque specifications.

Bracket Installation

CASE STX/NH TJ 375-425 MODELS

- REGULAR DUTY MODELS ONLY -

(Excluding QuadTRAC)

- Existing Holes - Not Used
- Existing Holes - Used to attach template and mount hydraulic coupler bracket.
- Holes to Drill - Used to attach side and axle brackets.

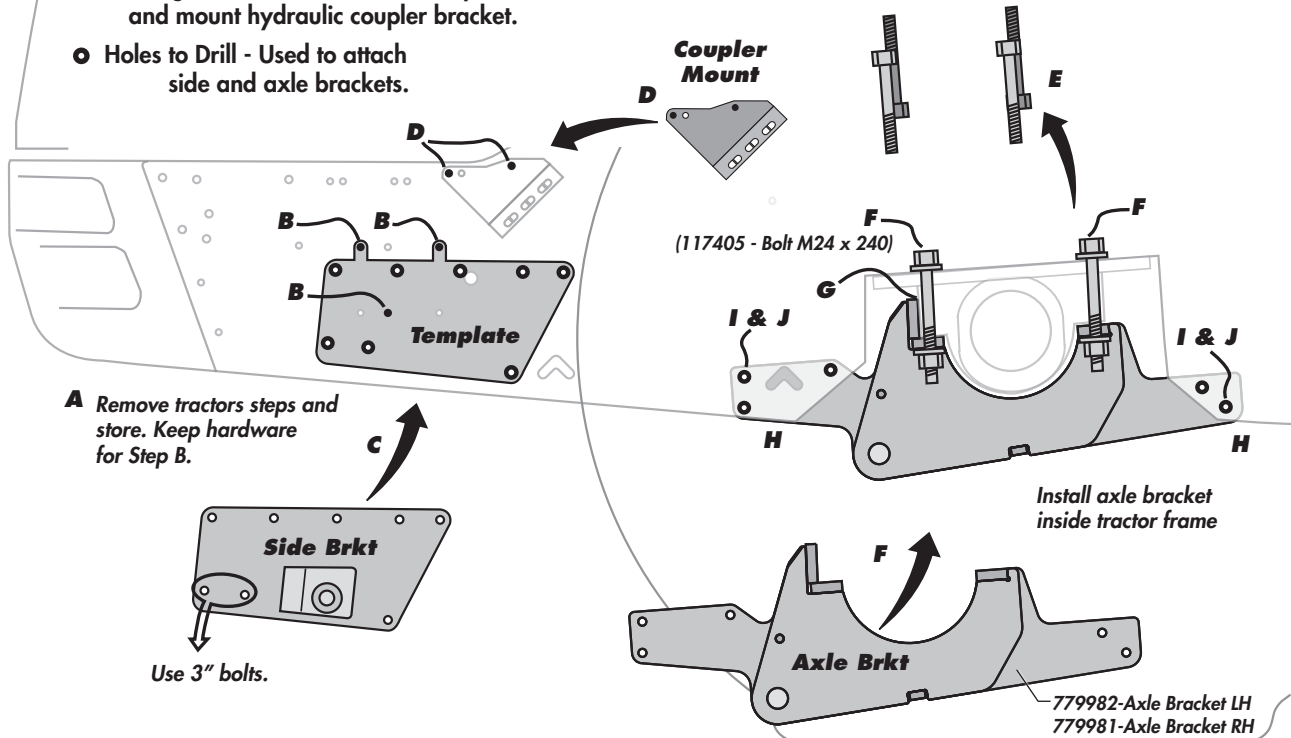

SIDE BRACKET INSTALLATION

- Remove tractor's steps. Keep hardware for mounting template. Store or discard steps.
- Mount template using existing holes & hardware (M12 bolts) from step removal. Center punch holes through template to scribe points, drill out to 13/16, and remove template.
- Install side bracket with the supplied 3/4 x 2-1/2 bolts in six of the holes, and with the supplied 3/4 x 3 bolts in last two holes as shown above.
- Install hydraulic coupler bracket using the hardware supplied.

AXLE BRACKET INSTALLATION

- Remove tractor's steps. Keep hardware for mounting template. Store or discard steps.
- Mount template using existing holes & hardware (M12 bolts) from step removal. Center punch holes through template to scribe points, drill out to 13/16, and remove template.
- Install side bracket with the supplied 3/4 x 2-1/2 bolts in six of the holes, and with the supplied 3/4 x 3 bolts in last two holes as shown above.
- Install hydraulic coupler bracket using the hardware supplied.

IMPORTANT-TORQUE



Torque all bolts properly!
Refer to maintenance
section for torque
specifications.

Bracket Installation

CASE STX/NH TJ 375-500 MODELS

- HEAVY DUTY MODELS ONLY -

(Excluding QuadTRAC)

- Existing Holes - Not Used
- Existing Holes - Used to attach template and mount hydraulic coupler bracket.
- Holes to Drill - Used to attach side and axle brackets.

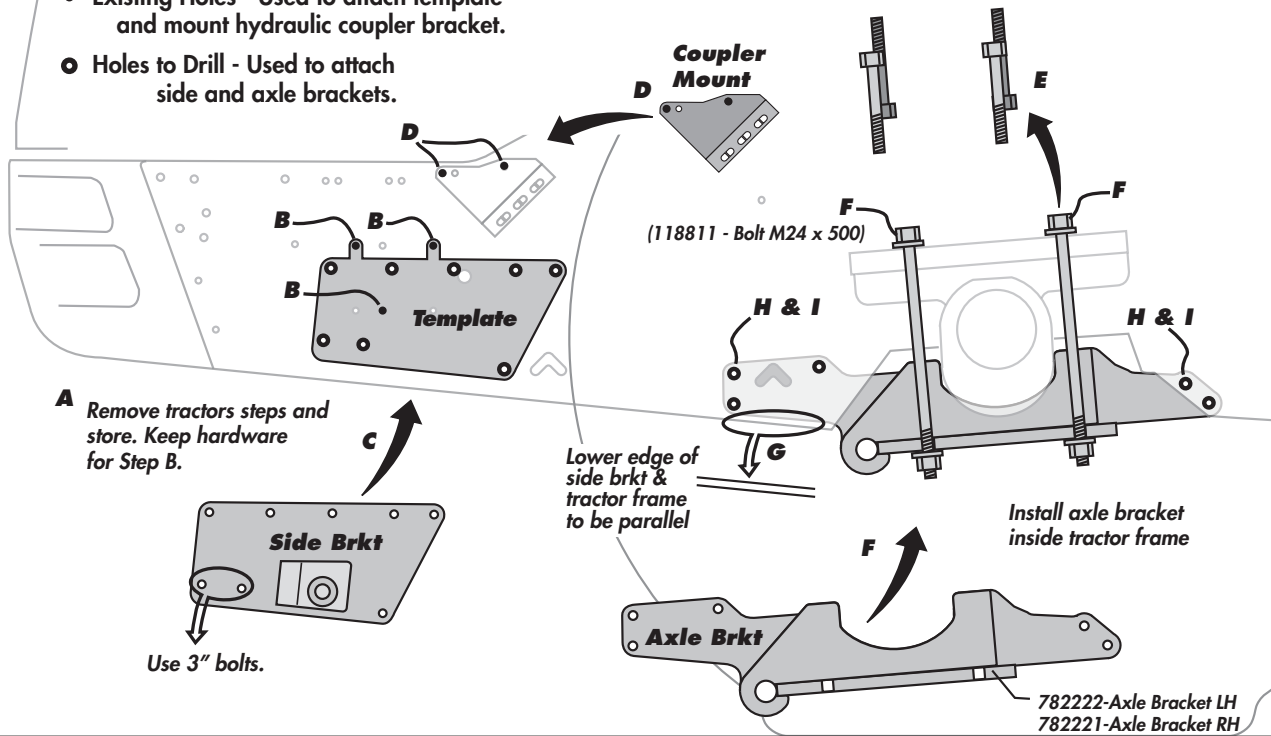

SIDE BRACKET INSTALLATION

- Remove tractor's steps. Keep hardware for mounting template. Store or discard steps.
- Mount template using existing holes & hardware (M12 bolts) from step removal. Center punch holes through template to scribe points, drill out to 13/16, and remove template.
- Install side bracket with the supplied 3/4 x 2-1/2 bolts in six of the holes, and with the supplied 3/4 x 3 bolts in last two holes as shown above.
- Install hydraulic coupler bracket using the hardware supplied.

AXLE BRACKET INSTALLATION

- Remove the existing M24 bolts (4), flat washers, & nuts holding the axle to the tractor frame. Please note bolt orientation. All hardware, except bolts, will be reused.
- Install Degelman axle bracket and loosely attach using the new supplied M24x500 bolts (4) and existing nuts and flat washers from Step E.
- Align bottom of bracket parallel to tractor frame as shown. Slightly tighten bolts (if required) until bracket is firm against axle casting. Clamp axle bracket in place. Double check parallel alignment.
- Drill out the five holes to 13/16 from inside tractor frame using axle bracket as template.
- Install with the supplied 3/4 x 2-1/2 bolts in all five places.

IMPORTANT-TORQUE



Torque all bolts properly!
Refer to maintenance section for torque specifications.

Bracket Installation

CASE STX QuadTRAC 375-500 MODELS

- Existing Holes - Not Used
- Existing Holes - Used to attach template and mount hydraulic coupler bracket.
- Holes to Drill - Used to attach side and axle brackets.

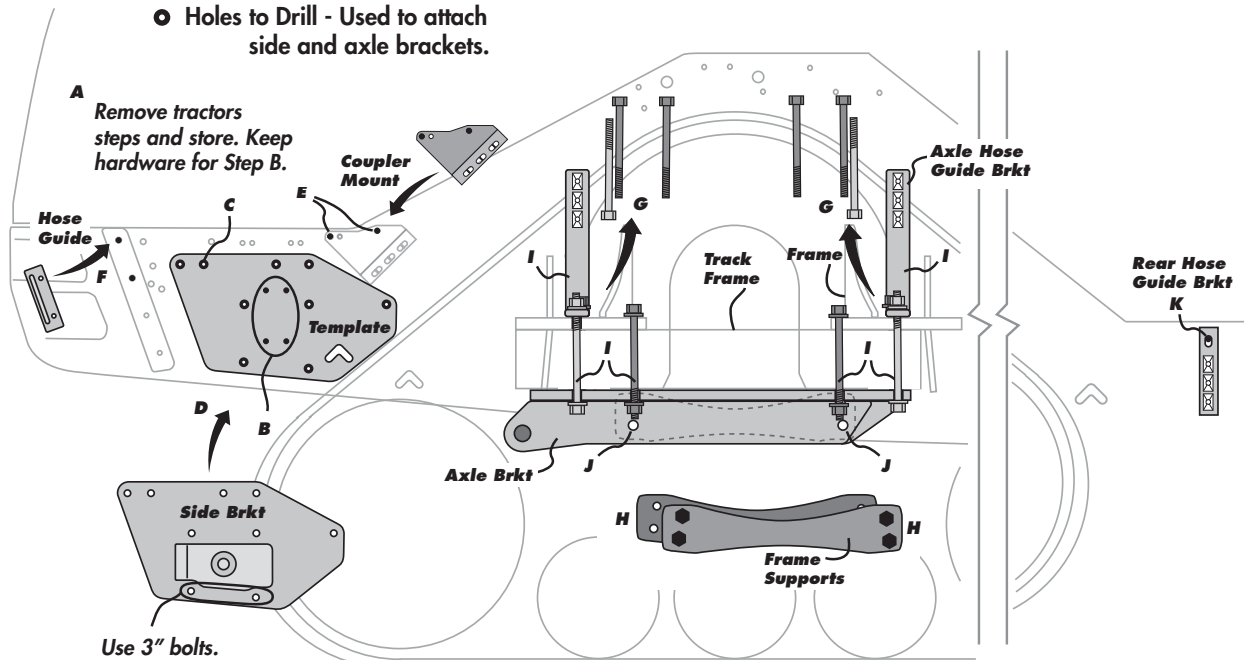

SIDE BRACKET INSTALLATION

- Remove tractor's steps. Keep hardware. Store or discard steps.
- Mount template using the four holes where the step was mounted. Attach using the step's bolts.
- Center punch through the remaining nine holes on template to scribe points. Remove template. Drill out to 13/16.
- Install side bracket with the supplied 3/4 x 2-1/2 bolts in seven of the holes & 3/4 x 3 bolts in the two holes shown.
- Install the hydraulic coupler bracket using the hardware supplied.
- Install hose guide. Spacer required with tow cable option (see page 5), otherwise, install with existing hardware.

AXLE BRACKET INSTALLATION

- Remove hardware holding track-frame to the tractor's frame. Please note bolt orientation. All hardware, except bolts (6), will be reused.
- Remove frame supports. All hardware will be reused. Store frame supports.
- Install axle bracket and axle hose guide brackets with the supplied M24x320 bolts (6) and existing hardware from Step G. Install hardware in same orientation as removed (two bolts nearest to the track are installed from below).
- Install the bolts and flat washers from Step H that held the frame supports in four places along with supplied M24 lock washers & nuts.
- Install the rear hose guide bracket with the supplied hardware.

IMPORTANT-TORQUE



Torque all bolts properly!
Refer to maintenance section for torque specifications.

Axle Bracket Hose Route

CASE STX/NH TJ 275 325

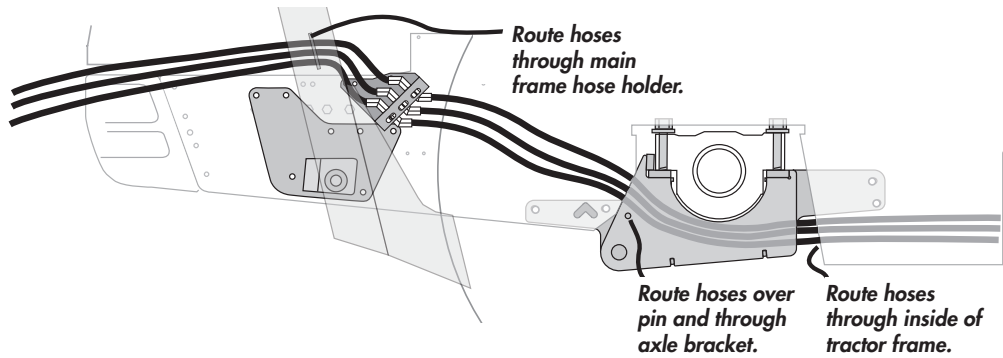

CASE STX/NH TJ 375-500

REGULAR DUTY MODELS

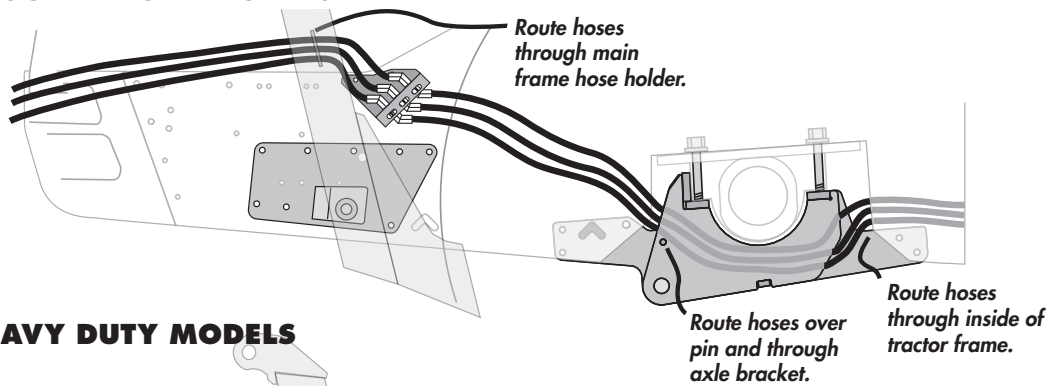

HEAVY DUTY MODELS

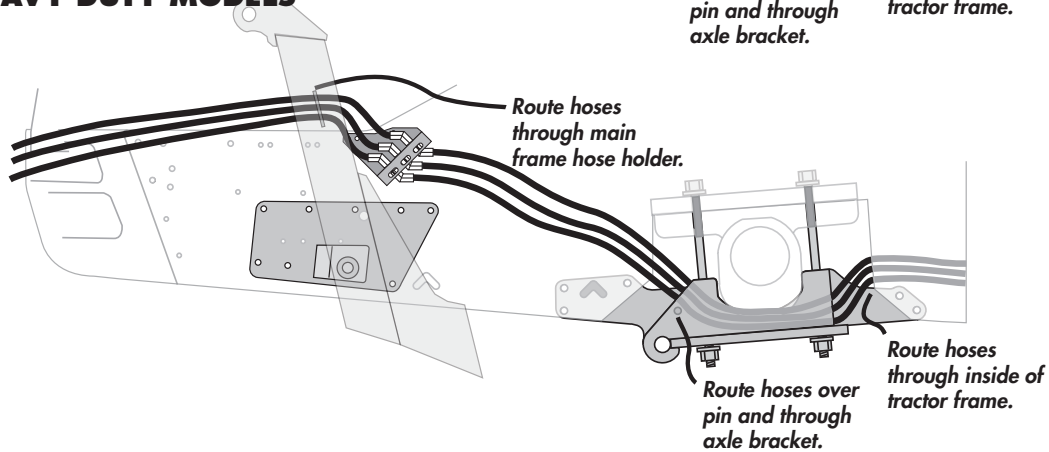

CASE STX QuadTRAC 375-500

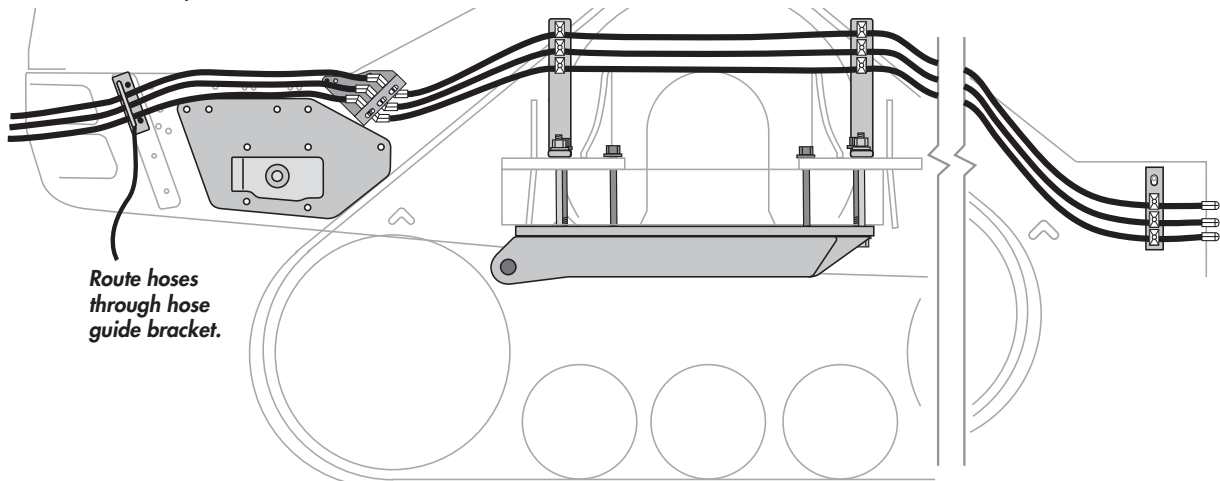

Cylinders

TILT CYLINDERS

123078 - Cylinder, 4" x 8" x 2"



123079 - Seal Kit

- 123236 - Pin, Kit - includes**
 122670 - Pin, 1-1/2" x 2-3/4" (2)
 118924 - Flat washer, .59" ID x .9" OD (2)
 118796 - Shoulder bolt, 1/2" GR8 UNC (2)

ALL MODELS

PREVIOUS: 122925 - Cylinder, 4" x 8" x 2"

-
- 118946 - Lock nut, 1-1/4" UNF GR5 unitorque (1)
 122774 - Piston (1)
 122927 - Barrel (1)
 122783 - Lock Ring (1)
 122781 - Open Cap (1)
 122932 - Rod & Clevis (1)
 122785 - Seal Kit (1)
 122670 - Pin, 1-1/2" x 2-3/4" (2)
 118924 - Flat washer, .59" ID x .9" OD (2)
 118796 - Shoulder bolt, 1/2" GR8 UNC (2)

LIFT CYLINDERS

123098 - Cylinder, 3-1/2" x 20" x 1-1/2"



123087 - Seal Kit

- 123236 - Pin, Kit - includes**
 122670 - Pin, 1-1/2" x 2-3/4" (2)
 118924 - Flat washer, .59" ID x .9" OD (2)
 118796 - Shoulder bolt, 1/2" GR8 UNC (2)

CASE STX/NH TJ 275-500

PREVIOUS: 122900 - Cylinder, 3-1/2" x 20" x 1-1/2"

-
- 118441 - Lock nut, 7/8 UNF GR5 unitorque (1)
 122663 - Piston (1)
 122902 - Barrel (1)
 122658 - Lock Ring (1)
 122656 - Open Cap (1)
 122906 - Rod & Clevis (1)
 122522 - Seal Kit (1)
 118796 - Shoulder bolt, 1/2" GR8 UNC (2)
 118924 - Flat washer, .59" ID x .9" OD (2)
 122670 - Pin, 1-1/2" x 2-3/4" (2)

LIFT CYLINDERS

123099 - Cylinder, 3-1/2" x 16" x 1-1/2"



123087 - Seal Kit

- 123236 - Pin, Kit - includes**
 122670 - Pin, 1-1/2" x 2-3/4" (2)
 118924 - Flat washer, .59" ID x .9" OD (2)
 118796 - Shoulder bolt, 1/2" GR8 UNC (2)

CASE STX QuadTRAC 375-500

PREVIOUS: 122700 - Cylinder, 3-1/2" x 16" x 1-1/2"

-
- 118441 - Lock nut, 7/8 UNF GR5 unitorque (1)
 122663 - Piston (1)
 122702 - Barrel (1)
 122658 - Lock Ring (1)
 122656 - Open Cap (1)
 122710 - Rod & Clevis (1)
 122522 - Seal Kit (1)
 118796 - Shoulder bolt, 1/2" GR8 UNC (2)
 118924 - Flat washer, .59" ID x .9" OD (2)
 122670 - Pin, 1-1/2" x 2-3/4" (2)

ANGLE CYLINDERS

123080 - Cylinder, 4" x 40-1/2" x 2-1/2"

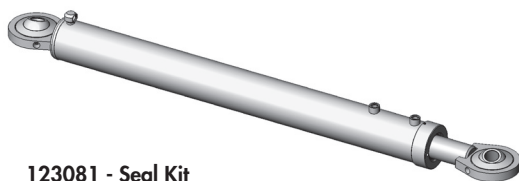

123081 - Seal Kit

ALL MODELS

PREVIOUS: 122980 - Cylinder, 4" x 40-1/2" x 2-1/2"

-
- 118946 - Lock nut, 1-1/4" UNF GR5 unitorque (1)
 122974 - Piston, Unitted (1)
 122962 - Rod & Ball (1)
 122922 - Barrel (1)
 122966 - Open Cap (1)
 122783 - Lock Ring (1)
 122978 - Seal Kit (1)



Hydraulic Routing - All Models Except QuadTRAC

TILT CYLINDER ROUTING

123078 - Cylinder, 4 x 8 x 2 (2)

Previously: 122925 - Cylinder (2)

- 25 126585 - Hose, 3/8 x 25 (2)
- 168 126626 - Hose, 3/8 x 168 (2)

- 2  141527 - Tee 3/4 JIC-m x JIC-m x ORB (2)
- 9  141504 - 90° Elbow, 3/4 JIC-m x ORB (2)

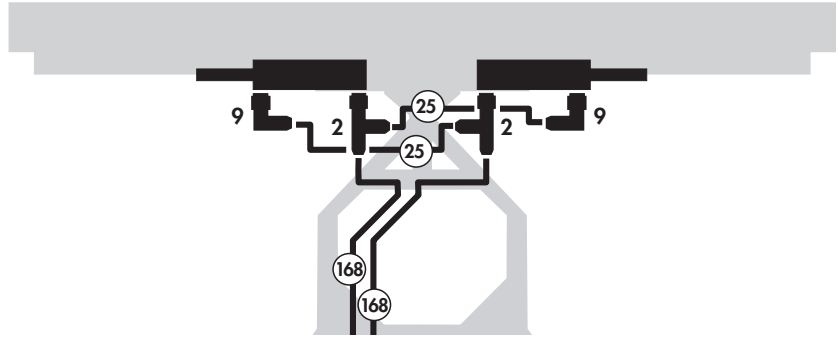





Refer to Front Hydraulic Connection Detail for connection options.

LIFT CYLINDER ROUTING

123098 - Cylinder, 3-1/2 x 20 x 1-1/2 (2)

Previously: 122900 - Cylinder (2)

- 75 126550 - Hose, 3/8 x 75 (1)
- 96 126551 - Hose, 3/8 x 96 (1)
- 100 126652 - Hose, 3/8 x 100 (1)
- 138 126645 - Hose, 3/8 x 138 (1)

- 2  141527 - Tee 3/4 JIC-m x JIC-m x ORB (2)
- 3  141518 - 90° Elbow, 3/4 JIC-m x JIC-f (1)
- 9  141504 - 90° Elbow, 3/4 JIC-m x ORB (1)
- 10  141515 - Connector, 3/4 JIC-m x ORB (1)

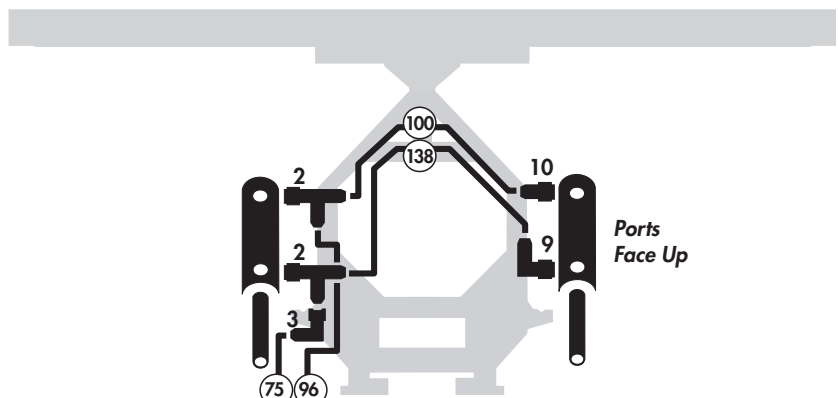









Refer to Front Hydraulic Connection Detail for connection options.

ANGLE CYLINDER ROUTING

123080 - Cylinder, 4 x 40-1/2 x 2-1/2 (2)

Previously: 122980 - Cylinder (2)

- 118 126650 - Hose, 3/8 x 118 (2)
- 120 126628 - Hose, 3/8 x 120 (2)
- 1  126675 - Hose, 3/8 x 5-5/8 - 2WB 3/4 JIC F-SW W/EL (2)
- 2  141527 - Tee 3/4 JIC-m x JIC-m x ORB (1) (2)
- 3  141518 - 90° Elbow, 3/4 JIC-m x JIC-f (2)
- 5  141506 - Orifice Plate, 0.07" ID (2)
- 8  141505 - Tee, 3/4 JIC-m x ORB x JIC-m (2)
- 9  141504 - 90° Elbow, 3/4 JIC-m x ORB (1) (2)
- 10  141515 - Connector, 3/4 JIC-m x ORB (2)
- 18  141503 - Tee, 3/4 JIC-F-SW x m x m (1)

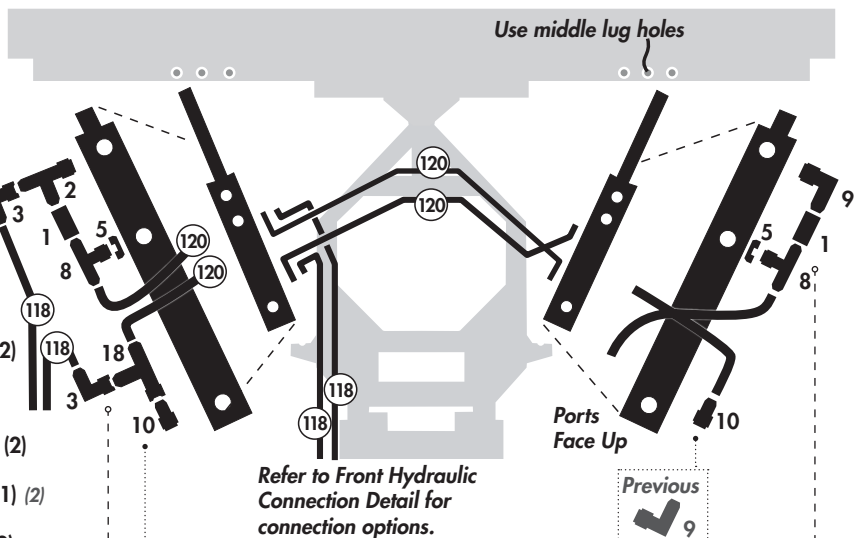

Refer to Front Hydraulic Connection Detail for connection options.



Hydraulic Routing - QuadTRAC Models

TILT CYLINDER ROUTING

123078 - Cylinder, 4 x 8 x 2 (2)

Previously: 122925 - Cylinder (2)

25 126585 - Hose, 3/8 x 25 (2)

144 126552 - Hose, 3/8 x 144 (2)

2  141527 - Tee 3/4 JIC-m x JIC-m x ORB (2)

9  141504 - 90° Elbow, 3/4 JIC-m x ORB (2)

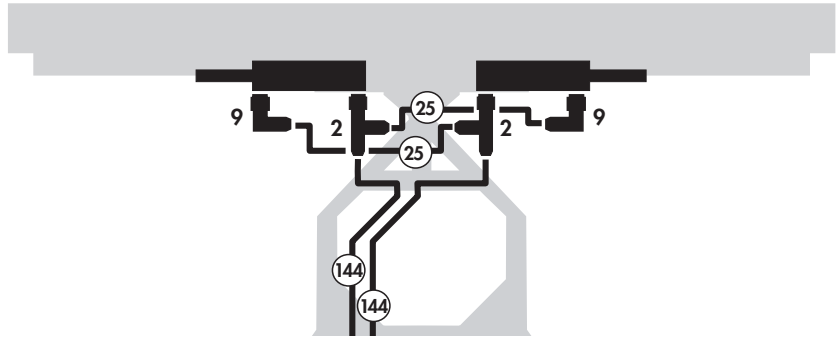

Refer to Front Hydraulic Connection Detail for connection options.

LIFT CYLINDER ROUTING

123099 - Cylinder, 3-1/2 x 16 x 1-1/2 (2)

Previously: 122700 - Cylinder (2)

66 126538 - Hose, 3/8 x 66 (1)

94 126541 - Hose, 3/8 x 94 (1)

100 126652 - Hose, 3/8 x 100 (2)

2  141527 - Tee 3/4 JIC-m x JIC-m x ORB (2)

3  141518 - 90° Elbow, 3/4 JIC-m x JIC-f (2)

9  141504 - 90° Elbow, 3/4 JIC-m x ORB (2)

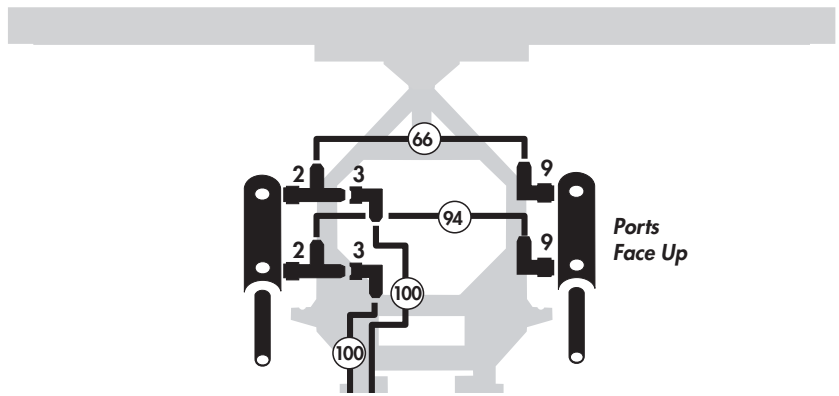

Refer to Front Hydraulic Connection Detail for connection options.

ANGLE CYLINDER ROUTING

123080 - Cylinder, 4 x 40-1/2 x 2-1/2 (2)

Previously: 122980 - Cylinder (2)

75 126550 - Hose, 3/8 x 75 (2)

82 126503 - Hose, 3/8 x 82 (2)

120 126628 - Hose, 3/8 x 120 (2)

1  126675 - Hose, 3/8 x 5-5/8 - 2WB
3/4 JIC F-SW W/EL (2)

3  141518 - 90° Elbow, 3/4 JIC-m x JIC-f (2)

5  141506 - Orifice Plate, 0.07" ID (2)

8  141505 - Tee, 3/4 JIC-m x ORB x JIC-m (2)

9  141504 - 90° Elbow, 3/4 JIC-m x ORB (2) (4)

10  141515 - Connector, 3/4 JIC-m x ORB (2)

13  141501 - Tee, 3/4 JIC-m (2)

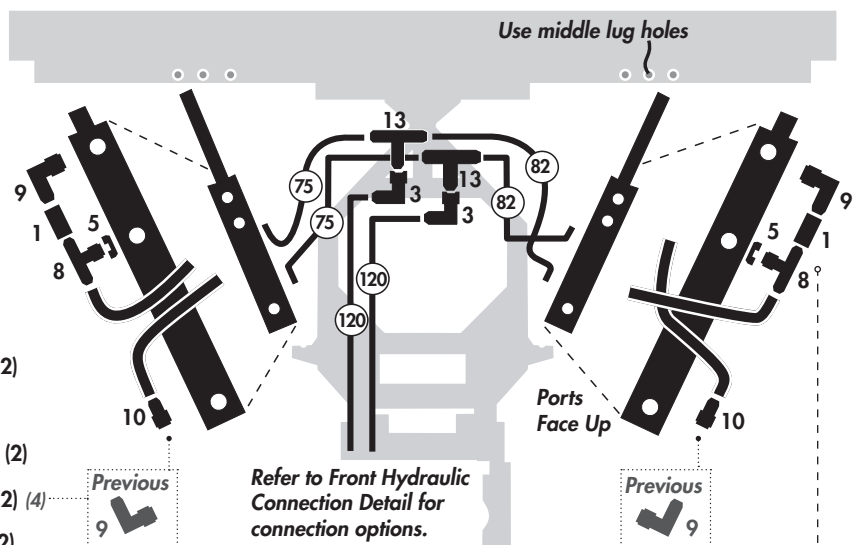



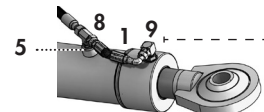





Refer to Front Hydraulic Connection Detail for connection options.

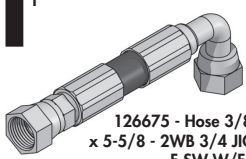
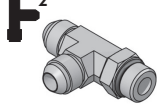
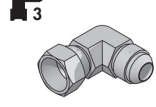
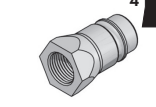

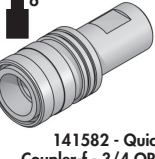
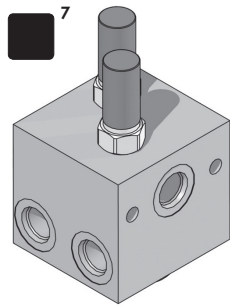
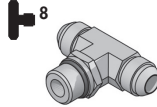
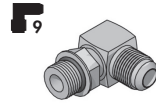
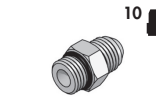
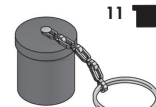

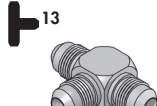

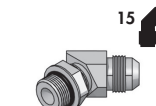

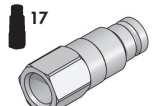
Hydraulic Routing

COMMON HYDRAULIC FITTINGS

This is a quick visual reference of the most common hydraulic fittings used in 7900 dozer blade hydraulic systems. The icon and numbers are used for reference in the routing diagrams on the following pages. Please note, this particular fit-up may not use all fitting types shown in the reference chart below.

 <p>126675 - Hose 3/8 x 5-5/8 - 2WB 3/4 JIC F-SW W/EL</p>	 <p>141527 - Tee 3/4 JIC-m x JIC-m x ORB</p>	 <p>141518 - 90° Elbow 3/4 JIC-m x JIC-f</p>	 <p>141581 - Quick Coupler-m - 3/4 ORB</p>	 <p>141506 - Oriface Plate - 0.07" ID</p>	 <p>141582 - Quick Coupler-f - 3/4 ORB</p>
 <p>141574 - Relief Valve</p>	 <p>141505 - Tee 3/4 JIC-m x ORB x JIC-m</p>	 <p>141504 - 90° Elbow 3/4 m JIC x ORB</p>	 <p>141515 - Connector 3/4 m JIC x ORB</p>	 <p>141577 - Dust Cap Coupler-m</p>	 <p>118922 - Retaining Ring - 1-1/2</p>
	 <p>141501 - Tee 3/4 JIC-m</p>	 <p>141513 - 90° Elbow 3/4 JIC-m</p>	 <p>141616 - 45° Elbow 3/4 JIC-m x ORB</p>	 <p>141578 - Dust Plug Coupler-f</p>	 <p>141573 - Flush Face Coupler - 3/4 ORB</p>

FRONT HYDRAULIC CONNECTION DETAIL

- 15  141616 - 45° Elbow, 3/4 JIC-m x ORB (6)
- 4  141581 - Quick Coupler m-3/4 ORB (6)
- 11  141577 - Dust Cap-m (6)
- 16  141578 - Dust Plug-f (6)
- 12  118922 - Retaining Ring 1-1/2 (12)
- 6  141582 - Quick Coupler f-3/4 ORB (6)

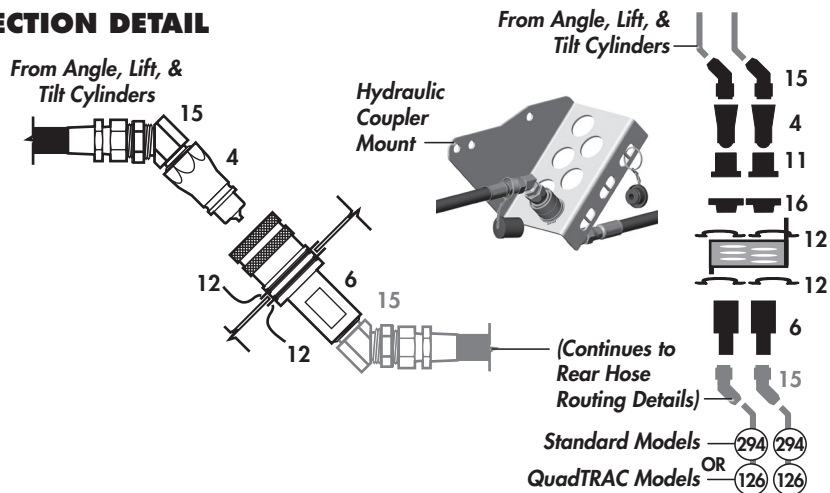

REAR RELIEF VALVE COMPONENTS

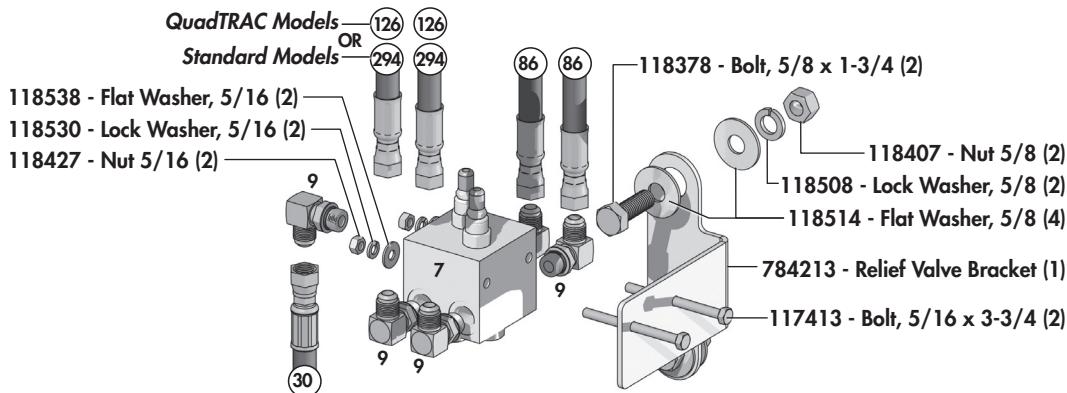

Hydraulic Routing

REAR HOSE ROUTINGS

CASE STX/NH TJ 275-500

Refer to Front Hydraulic Connection Detail.

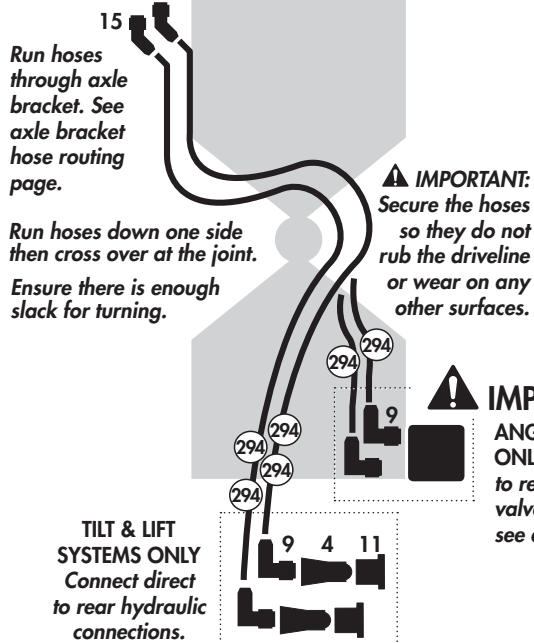

CASE STX QuadTRAC 375-500

Refer to Front Hydraulic Connection Detail.

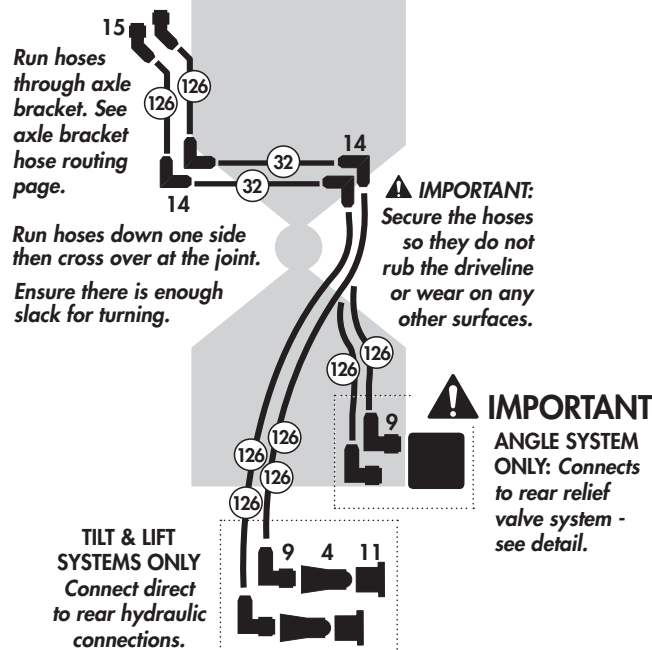

RELIEF VALVE CONNECTION DETAIL

! IMPORTANT

MUST be used on Angle Hydraulic System

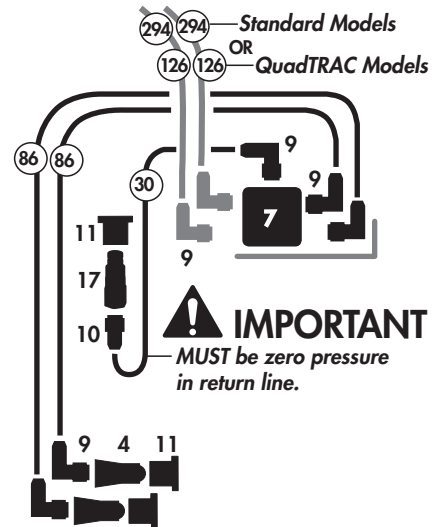

Connects to rear tractor hydraulic connections.

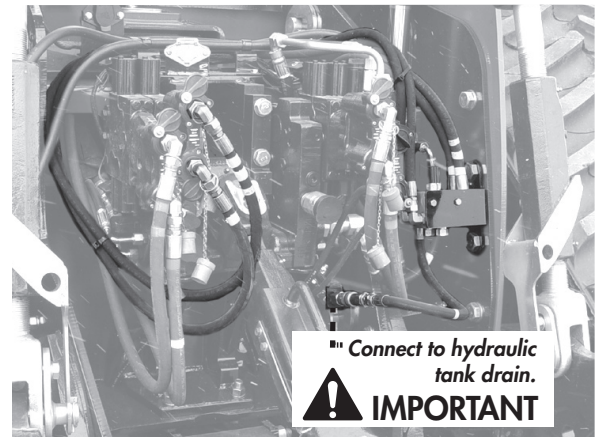

- (30) 126606 - Hose, 3/8 x 30 (1)
- (86) 126644 - Hose, 3/8 x 86 (2)
- (294) 126609 - Hose, 1/2 x 294 (6) Standard Models OR QuadTRAC Models
- (32) 126562 - Hose, 1/2 x 32 (6)
- (126) 126060 - Hose, 1/2 x 126 (12)

- 4 141581 - Quick Coupler-m - 3/4 ORB (6)
- 7 141574 - Relief Valve (1)
- 9 141504 - 90° Elbow, 3/4 JIC-m x ORB (9)
- 10 141515 - Connector, 3/4 JIC-m x ORB (1)
- 11 141577 - Dust Cap Coupler-m (7)
- 14 141513 - 90° Elbow 3/4 JIC-m (12) QuadTRAC Models
- 15 141616 - 45° Elbow, 3/4 JIC-m x ORB (6)
- 17 141573 - Flush Face Coupler - 3/4 ORB (1)

D-lock® Quick-Tach Operation

D-LOCK® COMPONENTS

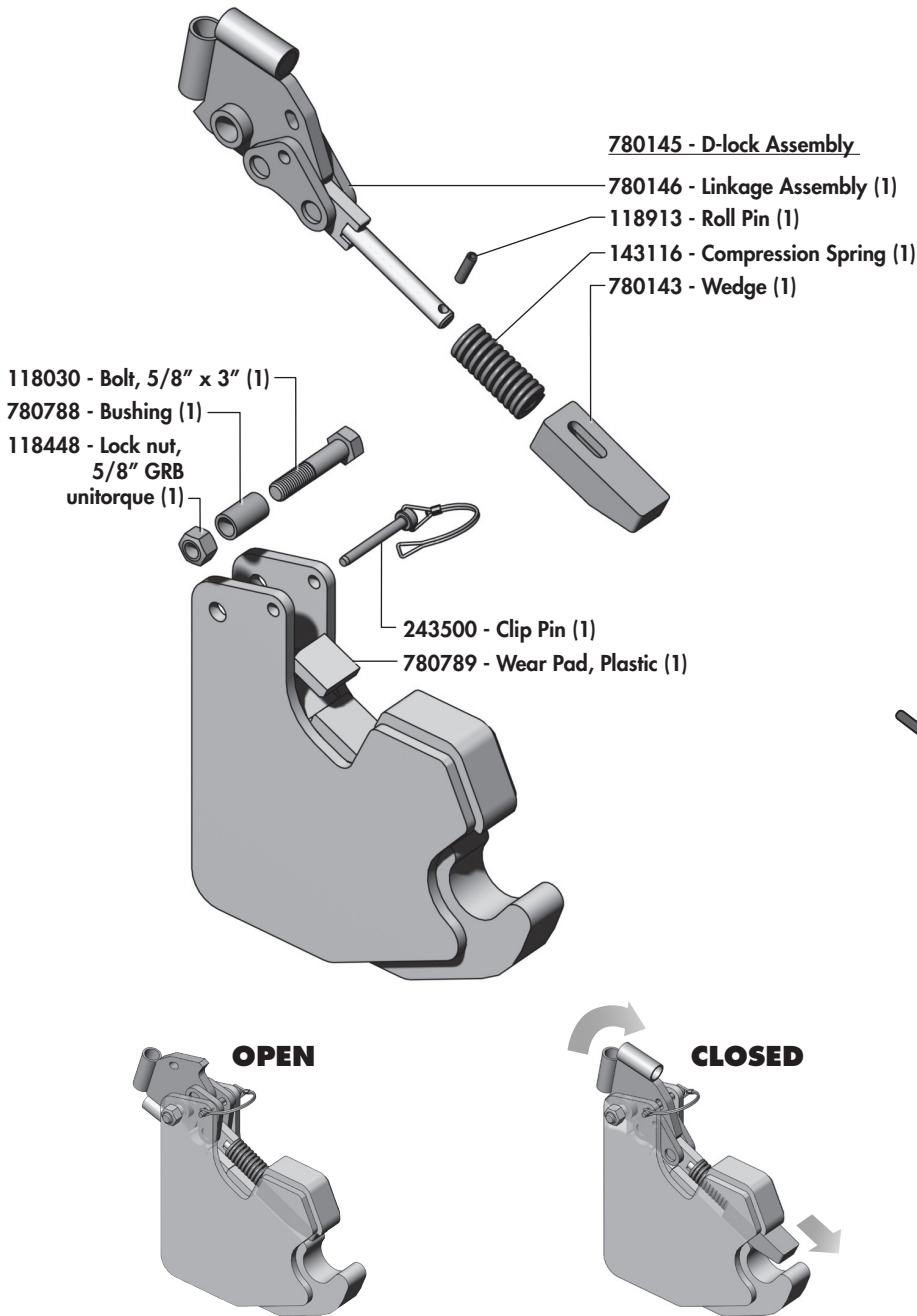

D-LOCK® OPERATION

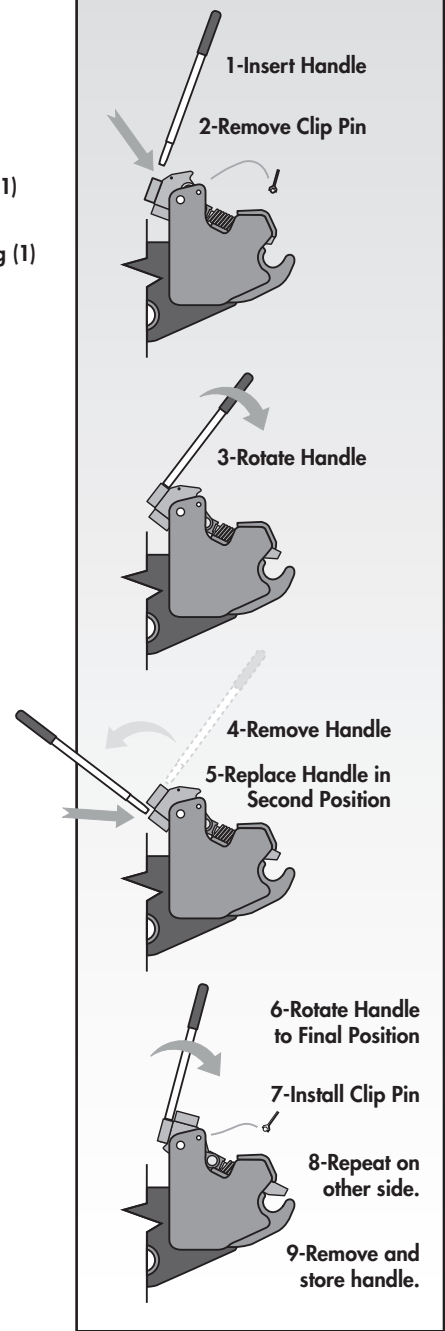

D-LOCK® HANDLE OPTIONS

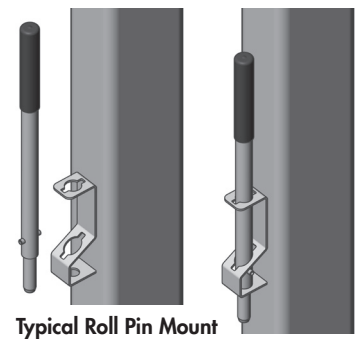
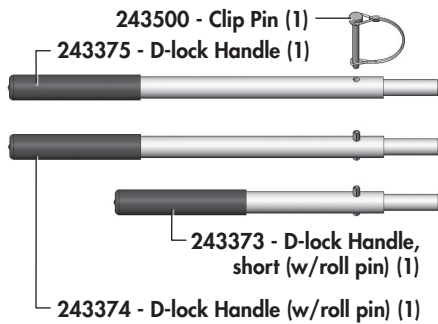
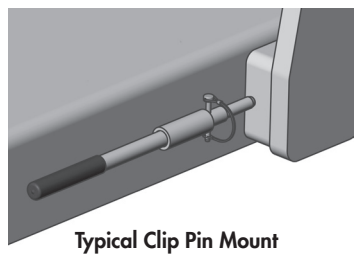

Mounting

Please note: The brackets and frame assembly for your particular fit-up may differ significantly from those used in the diagram, however, the procedure steps remain the same.

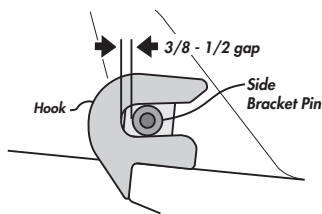
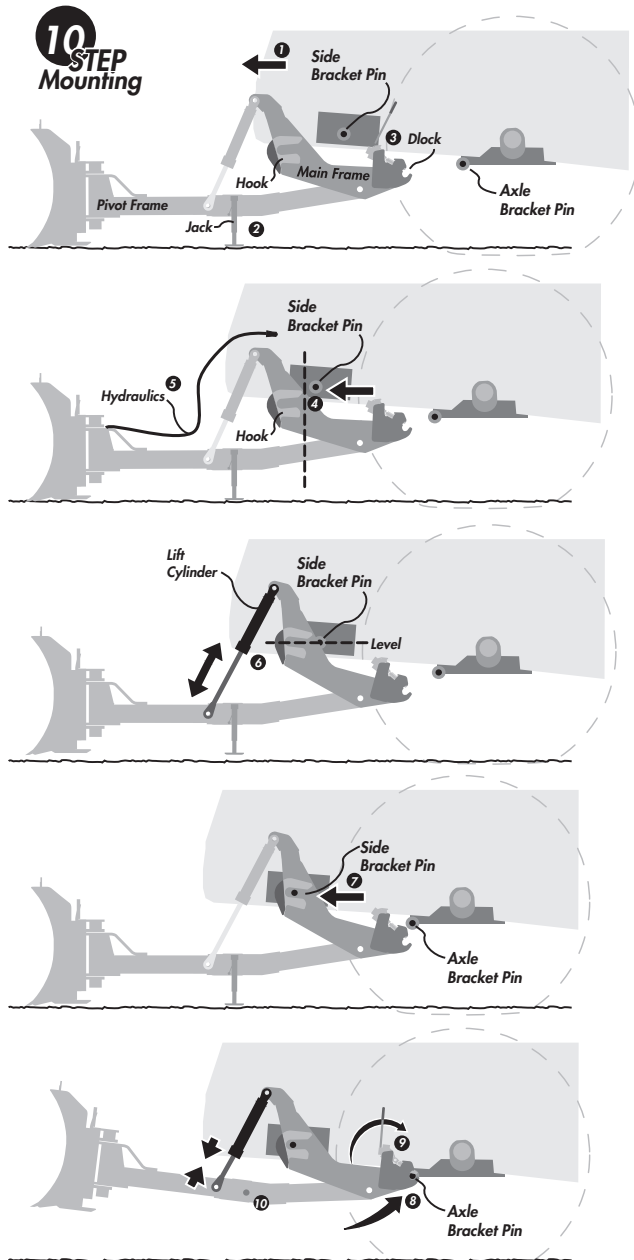

⚠ Important: There should be a small gap (3/8"-1/2") between the inside of the hook to the front of the bracket pin.

10 STEP MOUNTING

Procedure to mount blade:

1. Align the tractor behind the main frame.
2. Jack up the pivot frame high enough so the main frame hook is just below the side bracket pin.
3. Open the D-locks and remove handle.
4. Drive forward until the pin is just behind the hook.
5. Hook up the hydraulics.
6. Extend the lift cylinders until the hooks are lifted up level with the side bracket pins.
7. Drive forward to engage the side bracket pins.
8. Close the lift cylinder bringing the D-lock connection points up to the axle bracket pins. (By closing the lift cylinder, the weight of the front of the blade swings the back frame upward, engaging the axle bracket pins.)
9. Close the D-lock connections using the handle. Install the D-lock clip pins and store the handle.
10. Remove frame jacks and place in their storage positions.

UNHOOKING - REMOVING BLADE

⚠ DANGER

Important: You must close lift cylinder & lift blade before unlatching D-lock! This transfers the weight to the front hooks and frees up the D-lock. Otherwise, the whole assembly may come crashing down.

Procedure to remove blade:

1. Close lift cylinder to lift blade.
2. Open D-lock latches.
3. Lower blade by extending the lift cylinders - main frame will disengage from brackets.
4. If applicable, use frame support jacks.
5. Check that connection points are disconnected and clear to back out.
6. Unhook hydraulics.
7. Back tractor out.

Warranty

2 Year Limited Warranty

Degelman Industries Ltd. ("Degelman") warrants to the original purchaser of any new Degelman equipment, purchased from an authorized Degelman dealer, that the equipment will be free from defects in material and workmanship for a period of two (2) years from the date of delivery, for non-commercial use (including farm, institutional, government, and municipality) and (1) year from the date of delivery for commercial use. The obligation of Degelman to the purchaser under this warranty is limited to the repair or replacement of defective parts in the first year and to the provision, but not the installation of replacement parts in the second year. Degelman reserves the right to inspect any equipment or parts which are claimed to have been defective in material or workmanship.

This warranty limits its replacement or repair coverage to what is consistent with the warranty of Degelman's suppliers of purchased components. Replacement or repair parts installed in the equipment covered by this limited warranty are warranted for ninety (90) days from the date of delivery of such part or the expiration of the applicable new equipment warranty period, whichever ever occurs later. Warranted parts shall be provided at no cost to the user at an authorized Degelman dealer during regular working hours. Warranted replacement parts will either be replaced or rebuilt at Degelman's discretion.

Disclaimer of implied warranties & consequential damages

This warranty shall not be interpreted to render Degelman Industries Ltd. liable for injury, death, property damage or damages of any kind, whether direct, consequential, or contingent to property. Without limiting the generality of the foregoing, Degelman shall not be liable for damages resulting from any cause beyond its reasonable control, including, without limitation, loss of crops, any expense or loss of labour, supplies, rental machinery or loss of use.

No other warranty of any kind whatsoever, express or implied is made with respect to this sale; and all implied warranties of merchantability and fitness for a particular purpose which exceed the obligations set forth in this written warranty are hereby disclaimed and excluded from this sale. This exclusion shall not apply in any jurisdiction where it is not permitted by law.

This limited warranty shall not apply:

1. If, in the sole opinion of Degelman, the unit has been subjected to misapplication, abuse, misuse, negligence, accident or incorrect installation.
2. To any goods that have sustained damage or deterioration attributable to a lack of routine maintenance (eg. Re-torque of mounting hardware.)
3. If parts not made or supplied by Degelman have been used in the connection with the unit, if, in the sole judgement of Degelman such use affects its performance, safety, stability or reliability.
4. If the unit has been altered or repaired outside of an authorized Degelman dealership in a manner which, in the sole judgement of Degelman, affects its performance, safety, stability or reliability.
5. To expendable or wear items such as cutting edges, skid shoes, and any other items that in the company's sole judgement is a wear item.

No employee or representative of Degelman Industries Ltd. is authorized to change this limited warranty in any way or grant any other warranty unless such change is made in writing and signed by the Degelman Service Manager.

This limited warranty is subject to any future availability of supply, which may directly affect Degelman's ability to obtain materials or manufacture replacement parts.

Degelman reserves the right to make improvements in design or changes in specifications at any time, without incurring obligations to owners of equipment previously delivered.

This limited warranty is subject to compliance by the customer to the enclosed *Retail Customer's Responsibility Under Degelman Warranty*.

Make certain the warranty registration card has been forwarded to:

 **МОСТ ГРУПП**
150000. Ярославль
ул. Большая Октябрьская, 30-16
Тел. 8 800 201 1280
Факс +7 485 230 4100
E-Mail: mostgroup.ru@gmail.com
Http: www.most-technics.ru

Degelman Industries Ltd.
Box 830
272 Industrial Dr.
Regina, SK, Canada
S4P 3B1